

Legend GT

PROCHEM

Kärcher Group

Mobile Cleaning Unit

Operating Instructions (ENG)

MODELS: **LEGEND GT**
 1.001-119.0
 1.001-138.0
 1.001-141.0
 1.001-162.0

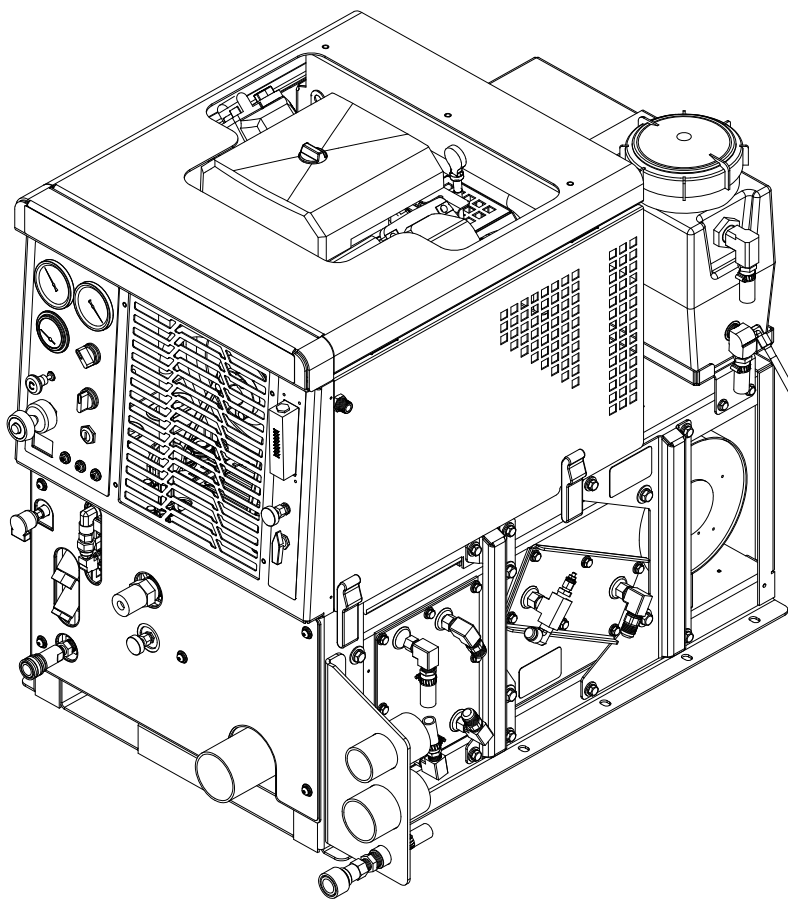

From Serial Number (Ref No1*)
*See Serial Number Page in Spare
Parts List or call manufacturer



86411060-B 08/25/16

Model: _____
Date of Purchase: _____
Serial Number: _____
Dealer: _____
Address: _____
Phone Number: _____
Sales Representative: _____

Overview

Welcome...and congratulations on the purchase of your Mobile Cleaning Unit. This instruction manual is a guide for operating and servicing your unit. **Read this manual completely before installing or operating this unit.** This unit offers you personal convenience. All of your instrumentation and controls have been positioned to give you easy access for operation and daily maintenance.

Proper operation and service are essential to the efficient functioning of this unit. When maintained correctly, this unit will have a long, trouble-free life.

The service methods described in this manual are explained in such a manner that servicing may be performed accurately and safely. Proper service varies with the choice of procedure, the skill of the mechanic, and the tools or parts available. Before attempting any repair, make certain that you are thoroughly familiar with this equipment and are equipped with the proper tools. Any questions pertaining to operating or servicing this unit should be directed to your nearest dealer.

THIS UNIT MUST BE INSTALLED BY THE DEALER FROM WHOM YOU PURCHASED IT IN ACCORDANCE WITH THE PRESCRIBED INSTALLATION PROCEDURES.

Information in this document is subject to change without notice and does not represent a commitment on the part of PROCHEM.

Warranty Registration

Thank you for purchasing a Prochem Kärcher Group product. Warranty registration is quick and easy. Your registration will allow us to serve you better over the lifetime of the product.

To register your product go to :
<http://www.prochem.com/WarrantyRegistration.aspx>

For customer assistance:

1-800-444-7654

PROCHEM

Kärcher Group

Receive a complementary package of Prochem Chemicals valued at \$250 with registration.

Table of Contents

Overview	1
Machine Data Label	1
Table of Contents	2
Receiving Your Unit	4
Acceptance of Shipment	4
Equipment List	4
How to Use This Manual	5

Safety

IMPORTANT SAFETY INSTRUCTIONS	6
Hazard Intensity Level	10
Safety Labels	12

Installation

Dealer Responsibility	14
Vehicle Requirements	14
Lifting Unit Onto Vehicle	14
Positioning Unit In Vehicle	14
Bolting Down Unit And Waste Tank	15
Electrical Wiring	15
Layout with 60 Gallon Waste Tank	16
Layout with 60 Gallon Waste Tank & Optional Auxiliary Water Tank	17
Layout with 100 Gallon Waste Tank	18
Layout with 100 Gallon Waste Tank & Optional Auxiliary Water Tank	19
Waste Tank To Console Connection	20
Fuel Pump Assembly Installation	20
Van Bulkhead Installation	21
Fuel Supply & Return Line Installation	22
Battery Connection	23
Initial Operational Settings	24

Operations

Technical Specifications	25
Fuel Requirements	26
Engine Oil Requirements	26
Altitude Requirements	26
Chemical Requirements	26
Water Requirements	27
Components	28
Vacuum System	31
Water Pumping and Heat Transfer System	32
Heat Exchanger	32
Chemical Injection System	34
Pre-Run Inspection / Setup	35
Check For Adequate Fuel	35
Remove Tools From Vehicle	35
Water Supply Connection	35
High Pressure Solution Hose	35
Vacuum Hose	35
Filters	35
Priming the Chemical Pump	36
Waste Pump (Optional)	36
Cleaning	36
Upholstery Cleaning	37
Shutdown and Daily Maintenance	37
De-Flooding Operations	37
Freezing Protection	37
Overheating Protection	37
Winterizing the Unit	38
Removing Anti-Freeze From the Unit	39

Maintenance

Service Schedule 40

Key Checkpoints 42

External Fuel Pump Maintenance 42

Chemical Supply System Maintenance 42

Heat Exchanger System Maintenance 42

Vacuum Pump Maintenance 43

Engine 43

Vacuum Pump 44

Solution Pump 45

Vacuum Inlet Filter (in Waste Tank) 45

Vacuum Relief Valve 45

Vacuum Pump Drive Belts 45

Solution Pump Drive Belts 46

Float Valve (Water Box) 46

Waste Tank Float Valve 46

Waste Tank Strainer Basket 46

Waste Tank Vacuum Inlet Filter 46

Check Valve (Outlet) 47

Chemical Pump 47

Chemical and Temperature Control Valves 47

Pressure Regulator 47

Vacuum Hoses 47

High Pressure Solution Hoses 47

Optional Waste Pump-Out 47

General Service Adjustments 48

Engine Speed 48

Check Valve (Solution Outlet) 48

Water Box 48

Chemical Pump 48

Solution and Vacuum Pump Drive Belts 49

Packing Nut Adjustments for Chemical Valves 49

Pressure Regulator 50

Troubleshooting 52

Acceptance of Shipment

Every part of your cleaning unit was carefully checked, tested, and inspected before it left our manufacturing plant. **Upon receiving the unit, make the following acceptance check:**

1. The unit should not show any outward signs of damage. If damaged, notify the common carrier immediately.
2. Check your equipment and packing list. The standard cleaning unit should arrive equipped with the following items (unless otherwise specified) and any optional accessories which were ordered:

Equipment List

1. Console.
2. Waste tank.
3. Fuel pump assembly.
4. 100 ft. of 2" vacuum hose.
5. 1 vacuum hose connector.
6. 100 ft. of 1/4" high pressure hose with quick connects.
7. 50 ft. water supply hose with quick connect.
8. Installation bolting kit.
9. Installation mounting plates.
10. Operation and service manuals for engine, solution pump, and vacuum pump.

This manual contains the following sections:

- How to Use This Manual
- Safety
- Installation
- Operations
- Maintenance & Service

The HOW TO USE THIS MANUAL section will tell you how to find important information for ordering correct repair parts.

Parts may be ordered from authorized dealers. When placing an order for parts, the machine model and machine serial number are important. Refer to the MACHINE DATA box which is filled out during the installation of your machine. The MACHINE DATA box is located on the inside of the front cover of this manual.

Model: _____
Date of Purchase: _____
Serial Number: _____
Dealer: _____
Address: _____
Phone Number: _____
Sales Representative: _____

The model and serial number of your machine is located approximately where shown

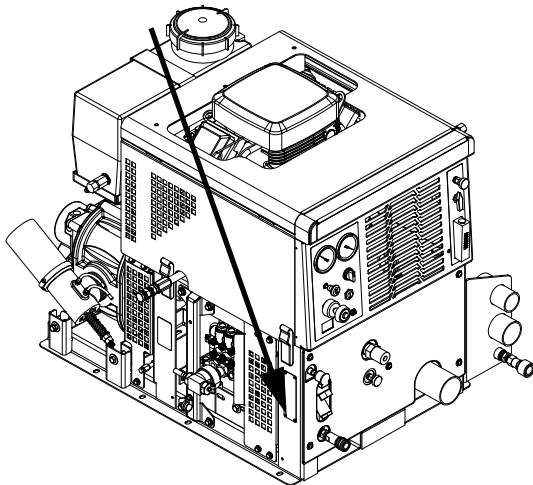

The SAFETY section contains important information regarding hazardous or unsafe practices for this machine. Levels of hazards are identified that could result in product damage, personal injury, or severe injury resulting in death.

The INSTALLATION section contains information on how to properly install the unit in your vehicle.

The OPERATIONS section is to familiarize the operator with the operation and function of the machine.

The MAINTENANCE section contains preventive maintenance to keep the machine and its components in good working condition. They are listed in this general order:

- Engine
- Vacuum Pump
- Solution Pump
- Drive Belts, Pulleys & Hubs
- Chemical Pump
- Hoses
- Exhaust Heat Exchanger
- General Service Adjustments
- Machine Troubleshooting

NOTE: If a service or option kit is installed on your machine, be sure to keep the KIT INSTRUCTIONS which came with the kit. It contains replacement parts numbers needed for ordering future parts.

NOTE: The manual part number is located on the lower right corner of the front cover.

IMPORTANT SAFETY INSTRUCTIONS

When using this machine, basic precaution
must always be followed, including the following:

READ ALL INSTRUCTIONS BEFORE USING THIS MACHINE.



These symbols mean **WARNING** or **CAUTION**. Failure to follow warnings and cautions could result in fatality, personal injury to yourself and/or others, or property damage. Follow these instructions carefully!



Read the operator's manual before installing or starting this unit. Failure to adhere to instructions could result in severe personal injury or could be fatal.

Operate this unit and equipment only in a well-ventilated area. Exhaust fumes contain carbon monoxide which is an odorless and deadly poison that can cause severe injury or fatality. **DO NOT** run this unit in an enclosed area. **DO NOT** operate this unit where the exhaust may enter any building doorway, window, vent, or opening of any type.

Gasoline is extremely flammable and its vapors can explode if ignited. Store gasoline only in approved containers, in well-ventilated, unoccupied buildings away from sparks or flames. Never carry any gasoline or flammable material in the vehicle. Fumes may accumulate inside the vehicle and ignite, causing an explosion.

DO NOT store any type of flammable material in the vehicle.

This unit must be operated with the vehicle or trailer doors open in order to ensure adequate engine ventilation.

DO NOT operate engine if gasoline is spilled. Avoid creating any ignition until the gasoline has been cleaned up. Never use gasoline as a cleaning agent.

DO NOT place hands, feet, hair, or clothing near rotating or moving parts. Avoid any contact with moving parts! Rotating machinery can cause injury or fatality.

Never operate this unit without belt guards. The high speed moving parts, such as belts and pulleys, should be avoided while this unit is running. Severe injury, damage, or fatality may result.

DO NOT service this unit while it is running. The high-speed mechanical parts as well as high temperature components may result in severe injury or severed limbs.

Never touch electrical wires or components while the engine is running. They can be sources of electrical shock.

Engine components can get extremely hot from operation. To prevent severe burns, **DO NOT** touch these areas while the engine is running or immediately after the engine is turned off.

DO NOT touch any part of the exhaust system while this unit is running. Severe burns may result.

Before servicing this unit, allow it to cool down. This will prevent burns from occurring.

Water under high pressure at high temperature can cause burns, severe personal injury, or fatality. Shut down machine, allow to cool down, and relieve system of all pressure before removing valves, caps, plugs, fittings, filters, and bolts.

Always wear hearing protection when unit is running. Always comply with your company's Personal Protection Equipment (PPE) plan. Always comply with local noise ordinance when operating units.

DO NOT leave the vehicle engine running while operating this unit.

Dangerous Acid, Explosive Gases! Batteries contain sulfuric acid. To prevent acid burns, avoid contact with skin, eyes and clothing. Batteries produce explosive hydrogen gas while being charged. To prevent a fire or explosion, charge batteries only in well ventilated areas. Keep sparks, open flames, and other sources of ignition away from the battery at all times. Keep batteries out of the reach of children. Remove all jewelry when servicing batteries.

Before disconnecting the negative (-) ground cable, make sure all switches are OFF. If ON, a spark will occur at the ground cable terminal which could cause an explosion if hydrogen gas or gasoline vapors are present. When disconnecting the battery, **ALWAYS** disconnect the negative (-) terminal **FIRST**.

DO NOT smoke around the unit. Gas fumes may accumulate and be ignited. The battery is also extremely flammable. This will prevent possible explosions.

DO NOT damage the vehicle in any manner during installation. When routing fuel lines **DO NOT** place the hose in any location where damage may occur to the hose or vehicle. Avoid any contact with moving parts, areas of high temperature, brake lines, fuel lines, muffler, catalytic converter, or sharp objects.

Use only Prochem supplied fuel installation kits. Ensure to use the kit specific for the truckmount model and van model being used. When traversing the vehicle floor with fuel lines, always use a bulkhead adapter. This will prevent leakage and ensure that the hose is not punctured by vehicle vibration abrasion.

DO NOT exceed your vehicle's weight limit. The console with empty 60 gallon waste tank and accessories weighs approximately 810 lbs (900 lbs. if mounted on water tank). Make certain to account for any additional accessories in your weight and balance calculations. Make certain that the vehicle has the correct axle rating. This will prevent unsafe vehicle driving conditions.

We require high-back seats on all vehicles in which units are to be installed for head and neck protection. We recommend using a metal partition between the seats and equipment.

DO NOT operate this unit without the water supply attached and turned on. The solution pump and other vital components may be seriously damaged if this unit is permitted to operate dry without water.

Keep your vehicle work area clean. Wands, stair tools, and other accessories must be securely fastened before driving the vehicle.

All high pressure hoses must be rated for 3000 PSI at 250°F. Thermoplastic hoses do not meet these specifications and should not be used. Severe burns and injury may result if the hoses do not meet these requirements.

The winterizing loop hose assembly, Part # 86260700, is for winterizing use only. If used improperly, live steam may escape from this hose, causing it to whip around. Burns or injury may result.

Make certain that you receive complete training by the distributor from whom you purchased this unit.

This unit uses high pressure and temperature. Improper or irresponsible use may result in serious injury.

Do not modify this unit in any manner. Improper modification can cause severe personal injury or fatality.

CALIFORNIA PROPOSITION 65 WARNING: Engine exhaust from this product contains chemicals known to the State of California to cause cancer, birth defects, or other reproductive harm. Running with out adequate water supply could damage water pump. Ensure always to have an adequate water supply.

READ AND SAVE THESE INSTRUCTIONS

MESURES DE SÉCURITÉ IMPORTANTES

Lors de l'utilisation d'un appareil à batteries, il est nécessaire de respecter systématiquement des mesures de sécurité de base, comme suit :

PRENEZ NOTE DE TOUTES CES MESURES AVANT D'UTILISER CETTE MACHINE.

⚠ AVERTISSEMENT:

⚠ ATTENTION:

Ces symboles signifient AVERTISSEMENT ou MISE EN GARDE. Le non-respect des avertissements et le non-respect des mises en garde pourraient entraîner la mort, causer des blessures à vous-même et/ou à autrui ou encore des dommages matériels. Veuillez suivre attentivement ces instructions!

Lire le manuel d'utilisation avant d'installer ou de démarrer cet appareil. Le non-respect de ces instructions pourrait causer des blessures graves ou pourrait avoir des conséquences fatales.

Utiliser cet appareil et cet équipement uniquement dans un endroit bien ventilé. Les gaz d'échappement contiennent du monoxyde de carbone qui est un gaz inodore et mortel pouvant causer des blessures graves ou entraîner la mort. **NE PAS** faire fonctionner cet appareil dans un endroit clos. **NE PAS** utiliser cet appareil dans un endroit où les gaz d'échappement risquent de pénétrer dans une entrée de porte, une fenêtre, un évent ou toute ouverture d'un édifice.

L'essence est extrêmement inflammable et ses vapeurs pourraient exploser lorsqu'elles sont enflammées. Entreposer l'essence uniquement dans des contenants approuvés, dans un bâtiment bien ventilé et non occupé, à l'écart des étincelles ou des flammes. Ne jamais transporter de l'essence ou des substances inflammables dans le véhicule. Les vapeurs pourraient s'accumuler à l'intérieur du véhicule et s'enflammer, causant une explosion.

N'entreposer AUCUN type de substance inflammable dans le véhicule.

Cet appareil doit être utilisé avec la porte du véhicule ou de la remorque ouverte afin de garantir une bonne ventilation du moteur.

NE PAS utiliser le moteur si du carburant a été renversé. Éviter de créer une source d'inflammation jusqu'à ce que le carburant ait été nettoyé. Ne jamais utiliser d'essence en tant qu'agent de nettoyage.

NE PAS placer les mains, les pieds, les cheveux ou les vêtements à proximité des pièces rotatives ou mobiles. Éviter tout contact avec les pièces mobiles! Les machines tournantes peuvent entraîner des blessures ou la mort.

Ne jamais utiliser cet appareil sans garde-courroie ou capot en place. Les pièces se déplaçant à haute vitesse, comme les courroies et les poulies, devraient être évitées durant le fonctionnement de cet appareil. Cela pourrait causer des blessures graves, des dommages ou la mort.

NE PAS réparer cet appareil pendant qu'il est en marche. Les pièces mécaniques se déplaçant à haute vitesse de même que les composantes à température élevée peuvent causer des blessures graves ou des amputations.

Ne jamais toucher aux fils ou composants électriques pendant que le moteur est en marche. Ils peuvent provoquer des chocs électriques.

Les composants du moteur peuvent devenir extrêmement chauds durant le fonctionnement. Pour éviter les brûlures, **NE PAS** toucher à ces zones pendant que le moteur est en marche - ou immédiatement après son fonctionnement.

NE PAS toucher au système d'échappement lorsque l'appareil est en marche. Cela pourrait causer des brûlures.

Laisser refroidir l'appareil avant d'en effectuer l'entretien. Cela permettra de prévenir les brûlures.

De l'eau sous haute pression dont la température est élevée peut causer des brûlures, des blessures graves ou la mort. Mettre l'appareil hors tension, le laisser refroidir et décompresser tout le système avant de retirer les soupapes, les capuchons, les bouchons, les raccords, les filtres et les boulons.

Toujours porter une protection de l'ouïe durant le fonctionnement de l'appareil. Toujours se conformer à l'ordonnance locale sur la protection contre le bruit lors de l'utilisation d'appareils.

NE PAS laisser tourner le moteur du véhicule lors de l'utilisation de cet appareil.

Acide dangereux, gaz explosifs! Les batteries contiennent de l'acide sulfurique. Pour prévenir les brûlures par acides, éviter tout contact avec la peau, les yeux et les vêtements. Les batteries produisent du gaz hydrogène explosif pendant la charge. Pour empêcher tout incendie ou toute explosion, charger les batteries uniquement dans des endroits bien ventilés. Garder la batterie à l'écart des étincelles, de la flamme nue et de toute autre source d'inflammation en tout temps. Garder les batteries hors de la portée des enfants. Enlever tous les bijoux au moment de procéder à l'entretien des batteries.

Avant de débrancher le câble de terre négatif (-), s'assurer que tous les commutateurs se trouvent en position OFF (arrêt). S'ils se trouvent en position ON (Marche), une étincelle au niveau de la borne du câble de terre pourrait causer une explosion si du gaz hydrogène ou des vapeurs d'essence sont présents. Au moment de déconnecter la batterie, **TOUJOURS** déconnecter d'ABORD la borne négative (-).

NE PAS fumer à proximité de l'appareil. Des émanations pourraient s'accumuler et prendre feu. La batterie est également extrêmement inflammable. Cela permettra de prévenir toute possibilité d'explosion.

NE PAS endommager le véhicule de quelque façon que ce soit durant l'installation. Lors de l'acheminement des conduits de carburant, **NE PAS** placer le flexible dans un endroit où le flexible ou le véhicule risquerait de subir des dommages. Éviter tout contact avec les pièces mobiles, les zones à température élevée, les conduites de frein, les conduits de carburant, le silencieux, le convertisseur catalytique ou les objets tranchants.

Utiliser uniquement des trousse d'installations de carburant fournies par Prochem. S'assurer d'utiliser une trousse spécifique aux modèles montés sur camion et camionnette. Au moment d'acheminer les conduits de carburant dans le plancher du véhicule, toujours utiliser un adaptateur passe-cloison. Cela permettra de prévenir les fuites et de s'assurer que le flexible ne soit pas perforé par les abrasions causées par la vibration du véhicule.

NE PAS excéder la limite de poids du véhicule. Le poids de la console avec le réservoir à décharge de 227 litres (60 gallons) et les accessoires est d'environ 460 kg (1 014 lb). S'assurer de tenir compte de tout accessoire supplémentaire au moment du calcul du poids et de l'équilibre. S'assurer que le calibre des essieux du véhicule est adéquat afin d'éviter des conditions de conduite dangereuses.

Nous exigeons des sièges baquets dans tous les véhicules dans lesquels des appareils sont installés pour une meilleure protection de la tête et du cou. Nous recommandons d'utiliser un cloison métallique entre les sièges et l'équipement.

NE PAS utiliser cet appareil si l'alimentation en eau n'est pas attachée et ouverte. La pompe à solution et les autres composants essentiels risqueraient d'être sérieusement endommagés si l'appareil fonctionne à sec sans eau. Le fonctionnement sans un approvisionnement en eau adéquat pourrait endommager la pompe à solution. S'assurer également que l'alimentation en eau est adéquate.

Garder la zone de travail du véhicule propre. Les lances, les outils pour marche d'escalier et les autres accessoires doivent être fermement attachés avant de conduire le véhicule.

Tous les flexibles de haute pression doivent avoir une capacité d'au moins 3 000 PSI à 121 °C (250 °F). Les flexibles thermoplastiques ne répondent pas à ces spécifications et ne devraient pas être utilisés. Des brûlures et des blessures graves peuvent être causées si les flexibles ne satisfont pas à ces exigences.

L'ensemble du flexible de boucle d'hivernisation, no de pièce 86260700, sert à l'hivernisation uniquement. Si elle n'est pas utilisée de façon adéquate, de la vapeur vive pourrait s'échapper de ce flexible et l'amener à fouetter l'air tout autour. Cela risquerait de causer des brûlures ou des blessures.

S'assurer de recevoir la formation complète par le distributeur auprès duquel l'appareil a été acheté.

L'appareil utilise des pressions et des températures élevées. Une utilisation inappropriée ou irresponsable pourrait causer des blessures graves.

Ne pas modifier cet appareil de quelque manière que ce soit. Toute modification inappropriée pourrait causer des blessures graves ou la mort.

AVERTISSEMENT EN VERTU DE LA PROPOSITION 65 DE L'ÉTAT DE LA CALIFORNIE : L'échappement du moteur de ce produit contient des agents chimiques connus, dans l'État de la Californie, comme pouvant causer le cancer, des anomalies congénitales ou d'autres problèmes liés à la reproduction.

CONSERVER CES INSTRUCTIONS

The following symbols are used throughout this guide as indicated in their descriptions:

Hazard Intensity Level

There are three levels of hazard intensity identified by signal words - **WARNING** and **CAUTION** and **FOR SAFETY**. The level of hazard intensity is determined by the following definitions:



WARNING - Hazards or unsafe practices which COULD result in severe personal injury or death.



CAUTION - Hazards or unsafe practices which could result in minor personal injury or product or property damage.

FOR SAFETY: To Identify actions which must be followed for safe operation of equipment.

Report machine damage or faulty operation immediately. Do not use the machine if it is not in proper operating condition. Following is information that signals some potentially dangerous conditions to the operator or the equipment. Read this information carefully. Know when these conditions can exist. Locate all safety devices on the machine. Please take the necessary steps to train the machine operating personnel.

FOR SAFETY:

DO NOT OPERATE MACHINE:

Unless Trained and Authorized.

Unless Operation Guide is Read and understood.

In Flammable or Explosive areas.

In areas with possible falling objects.

WHEN SERVICING MACHINE:

Avoid moving parts. Do not wear loose clothing; jackets, shirts, or sleeves when working on the machine. Use Prochem approved replacement parts.

Les symboles ci-dessous sont utilisés à travers ce manuel comme illustré dans leurs descriptions :

DEGRÉS DE RISQUES EN CAS DE DANGER

Il existe trois degrés de risques identifiés par les termes signalétiques –**AVERTISSEMENT** et **ATTENTION** et **POUR VOTRE SÉCURITÉ**. Le degré de risque est défini de la manière suivante:

⚠ AVERTISSEMENT:

AVERTISSEMENT - Dangers ou méthodes dangereuses qui POURRAIENT provoquer de graves blessures ou entraîner la mort.

⚠ ATTENTION:

ATTENTION - Dangers ou méthodes dangereuses qui pourraient provoquer des blessures légères ou une détérioration du produit ou des biens immobiliers.

POUR VOTRE SÉCURITÉ: ce signe permet d'identifier les mesures de précaution à prendre pour assurer un bon fonctionnement du matériel.

Rendre compte immédiatement d'une défaillance ou d'une détérioration de la machine. Ne pas utiliser la machine si celle-ci ne fonctionne pas correctement. Lire soigneusement les informations ci-dessous signalant certains dangers potentiels pour l'opérateur de la machine. L'opérateur doit être absolument au courant de ces dangers potentiels. Localiser tous les dispositifs de sécurité sur la machine. Il est conseillé de prendre les mesures nécessaires pour former le personnel opérateur.

POUR VOTRE SÉCURITÉ:

NE PAS MANOEUVRER LA MACHINE:

Lorsqu'on n'est pas expérimenté ou qualifié.

Lorsque le guide d'utilisation n'est pas été lu ou compris.

Dans des zones inflammables ou explosives.

Dans des zones où des objets peuvent tomber.

LORS DE L'ENTRETIEN DE LA MACHINE:

Éviter les parties amovibles. Ne pas porter de vêtements amples, tels que des vestes, des chemises ou des vêtements avec manches lors de l'utilisation de la machine. Utiliser les pièces détachées homologuées.

Safety Labels

The following **WARNING LABELS** are found on your cleaning unit. These labels point out important **Warnings** and **Cautions** which should be followed at **all** times. Failure to follow warnings and cautions could result in fatality, personal injury to yourself and/or others, or property damage. Follow these instructions carefully! **DO NOT** remove these labels.

NOTE: If at any time the labels become illegible, promptly replace them.

REMARQUE: Les schémas ci-dessous indiquent l'emplacement des plaques de sécurité. Si les plaques deviennent illisibles, les remplacer immédiatement.

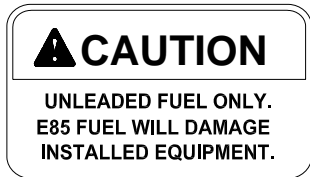

Caution Label
P/N 86352580
Installation on vehicle fuel door.



Warning Label
P/N 86412290

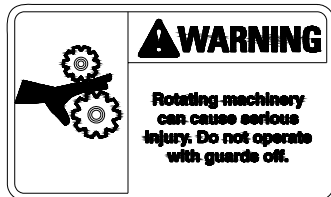
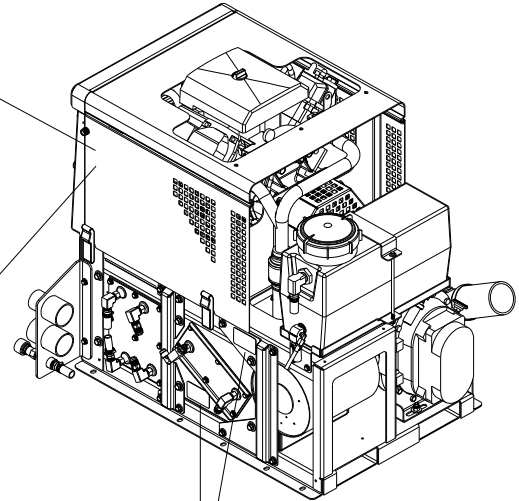

Warning Label
P/N 86186520



Warning Label
P/N 86412300



Caution Label
P/N 86186530

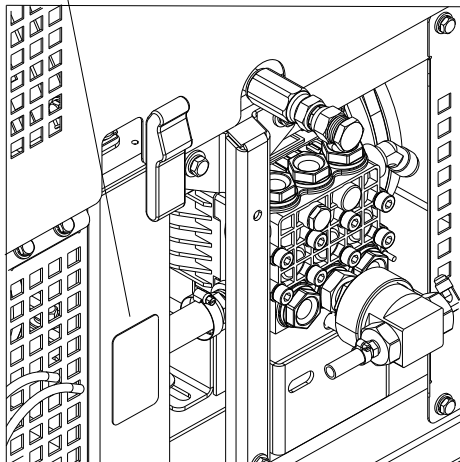

Lower Front Panel Decal
P/N 86409230

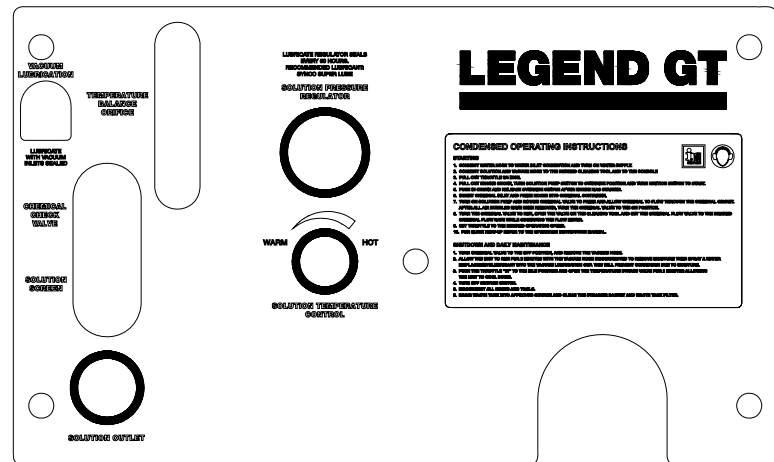

Dealer Responsibility

Your distributor from whom you purchased this mobile cleaning unit is responsible for correct installation of this machine. The dealer is also responsible for initial training of your operators and maintenance personnel in proper operation and maintenance of this unit.

Vehicle Requirements

1. The unit should NOT be mounted in any motor vehicle of less than 1/2 ton capacity or **3/4 ton** if equipped with one or more auxiliary fresh water tanks.

CAUTION:

DO NOT exceed the vehicle's axle weight limit. Include the console, full tanks, accessories, and operators in calculations.

ATTENTION:

NE PAS excéder la limite de poids des essieux du véhicule. Inclure la console, les réservoirs pleins, les accessoires et les opérateurs au moment d'effectuer les calculs.

2. If mounting in a trailer, make certain that trailer is rated for the total weight of **UNIT AND TRAILER**. Electric or hydraulic brakes should be provided, and a strict compliance with any State and Federal vehicle laws must be maintained.
3. The vehicle tires should have a load rating above the combined vehicle and unit weight.
4. We do not recommend using flooring materials that absorb water. This could result in rust and corrosion of the vehicle floor.
5. Padding under rubber floor mats should be removed before installing this unit.
6. We highly recommend using a drip tray under console (Part #86050370, or Part # 86050380 for units mounted on a water tank).
7. If using a trailer, console should be positioned so that it balances properly with respect to axle. Ten percent (10%) of the overall unit weight, should be on tongue.

Example: If loaded trailer weight is 2,000 lbs., tongue weight needs to be a minimum of 200 lbs. to tow properly.

Lifting Unit Onto Vehicle

Since console weighs approximately 600 lbs. pounds, (690 lbs. if mounted on water tank) we recommend using a forklift to lift unit onto vehicle. Position forks under unit from front and make CERTAIN that forks are spread to insert into frame slots.

Positioning Unit In Vehicle

Because vehicles vary in size and openings, individuals have their own preference as to where they want their units installed. We strongly recommend a side door installation for this and **DO NOT** recommend a rear door installation.

1. Enough space should be provided to assure adequate engine ventilation and room for service and maintenance.
2. The unit with waste tank and accessories must **NOT** exceed vehicle's axle weight limit. An empty 60 gallon waste tank and console weighs 810 lbs (900 lbs. if mounted on water tank).
3. **DO NOT** position the console closer than 12" from bottom of driver and passenger seats.

NOTE: For individuals who wish to make an engineering layout prior to positioning unit, refer to "Dimensional Data" illustrations for waste tank and console dimensions.
4. Be sure to consider all accessories and their required space prior to positioning the console and waste tank.

Bolting Down Unit And Waste Tank

NOTE: When positioning waste tank with respect to console, hook up the vacuum hose to waste tank. This will ensure that waste tank is positioned correctly. Proceed once unit and waste tank are positioned in vehicle in desired location.

⚠ CAUTION:

Before drilling any mounting holes in vehicle floor, make certain that when drilling, you will not do any damage to fuel tank, fuel lines, or any vital component which might affect operation or safety of vehicle.

⚠ ATTENTION:

Avant de percer les trous de montage dans le plancher du véhicule, s'assurer que les trous ne causeront aucun dommage au réservoir à carburant, aux conduits de carburant ou tout autre composant essentiel qui pourrait affecter le fonctionnement ou la sécurité du véhicule.

1. Using console and waste tank mounting holes as a template, drill six 13/32" diameter holes for mounting console and six more 13/32" diameter holes for mounting waste tank.
2. Using installation hardware kit:
 - a. Insert six 3/8-16 x 2" hex head cap screws with flat washers through mounting holes in console, and six 3/8-16 x 2" hex head cap screws with flat washers through mounting holes in waste tank.
 - b. Install mounting plates underneath vehicle floor.
 - c. Screw 3/8-16 hex head locknuts on mounting screws and tighten them until console and waste tank are firmly secured to vehicle floor.

Electrical Wiring

Ensure all electrical wiring and battery cables are free from contact with any metal edge. Engine vibration could cause metal edge to cut wiring and possibly result in a fire. Be aware of where battery cables are run.

Layout with 60 Gallon Waste Tank

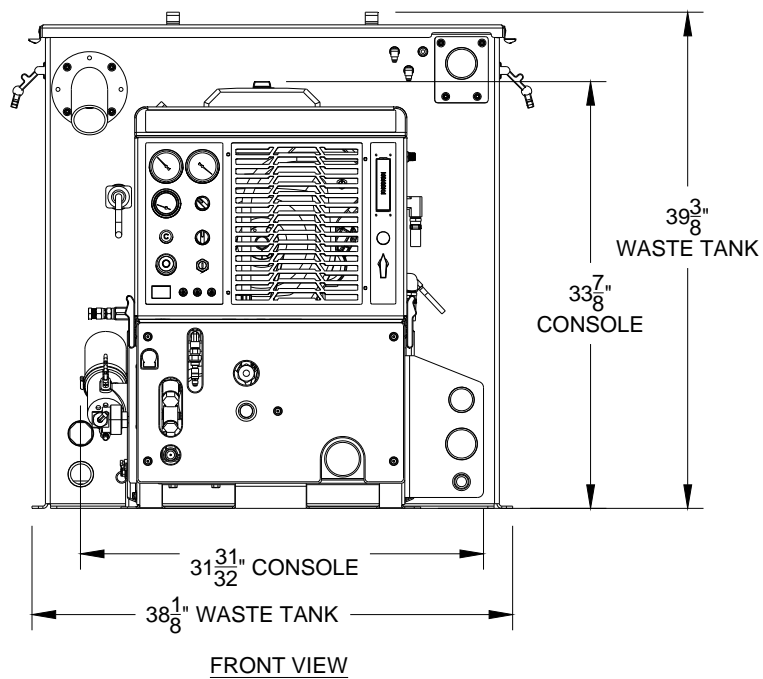
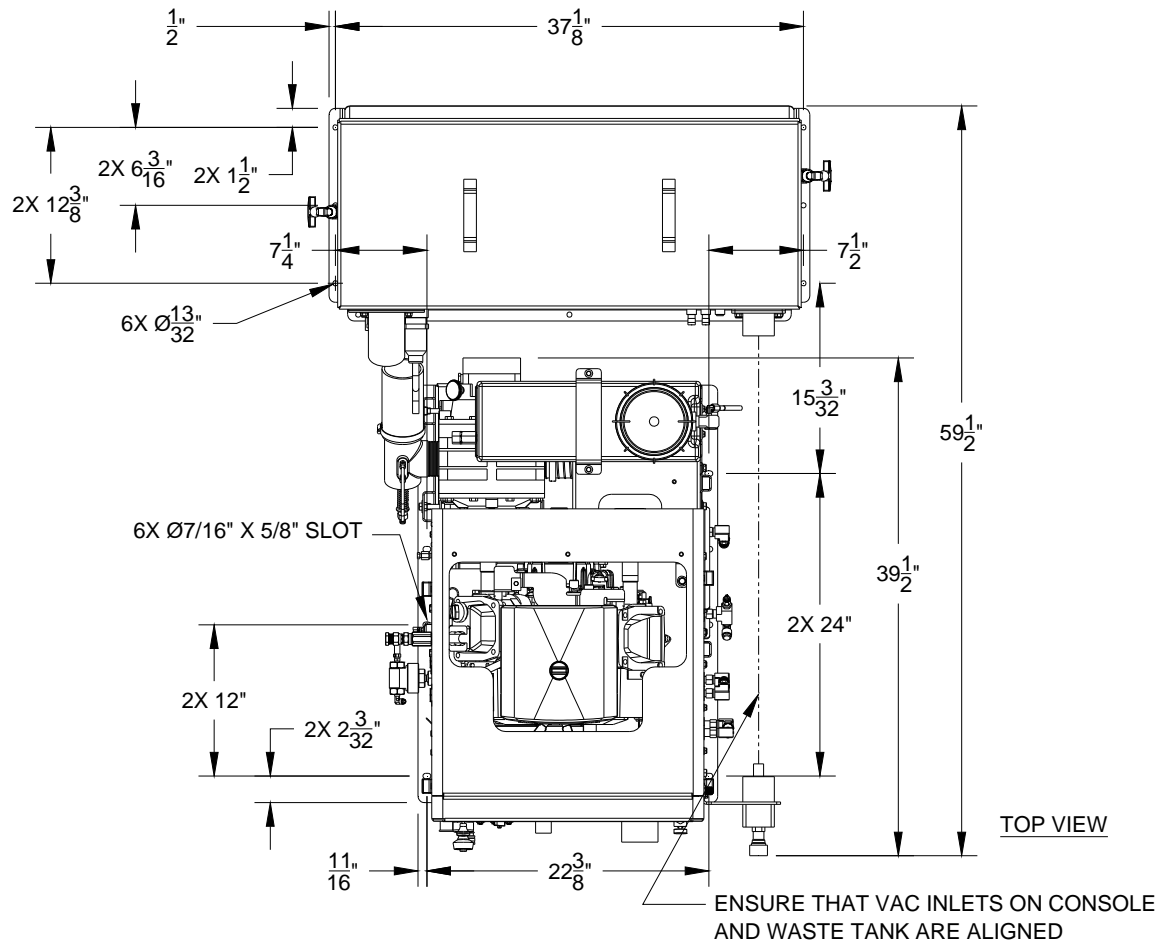

Layout with 60 Gallon Waste Tank & Optional Auxiliary Water Tank

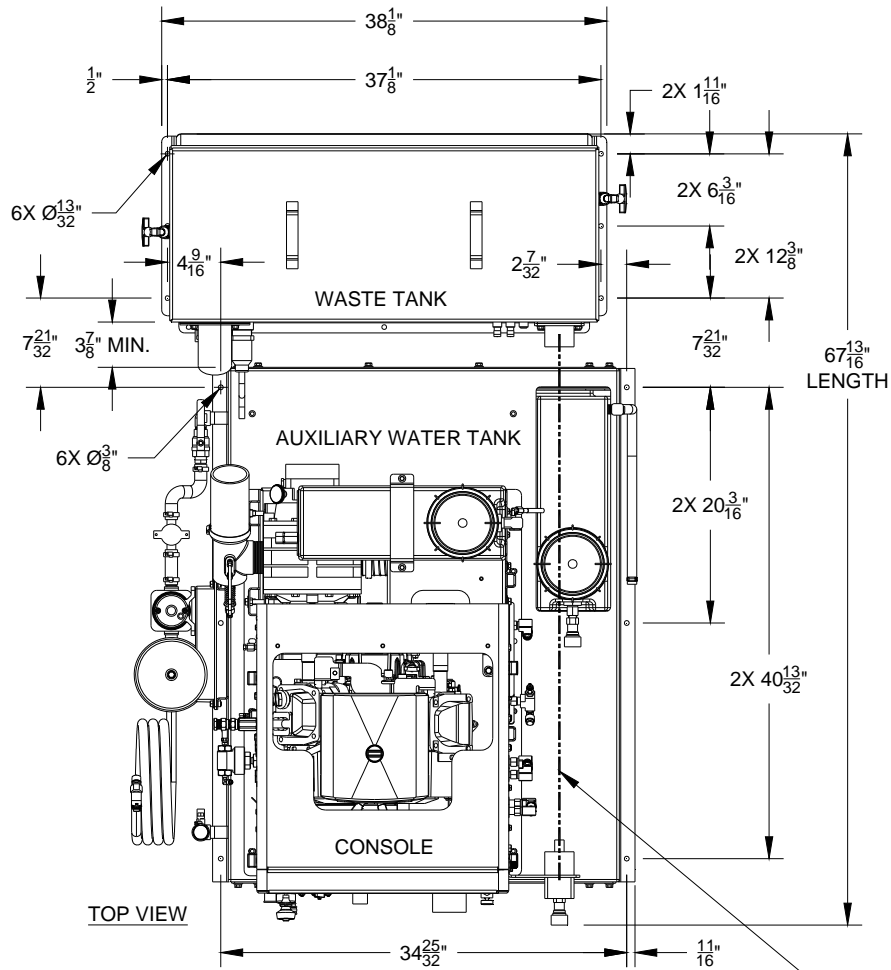

ENSURE THAT VAC INLETS ON CONSOLE AND WASTE TANK ARE ALIGNED

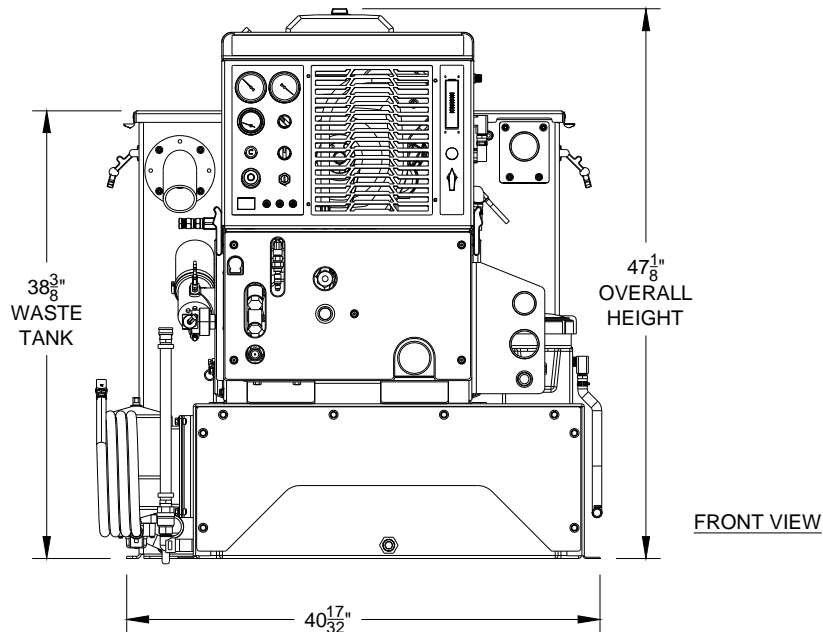

Layout with 100 Gallon Waste Tank & Optional Auxiliary Water Tank

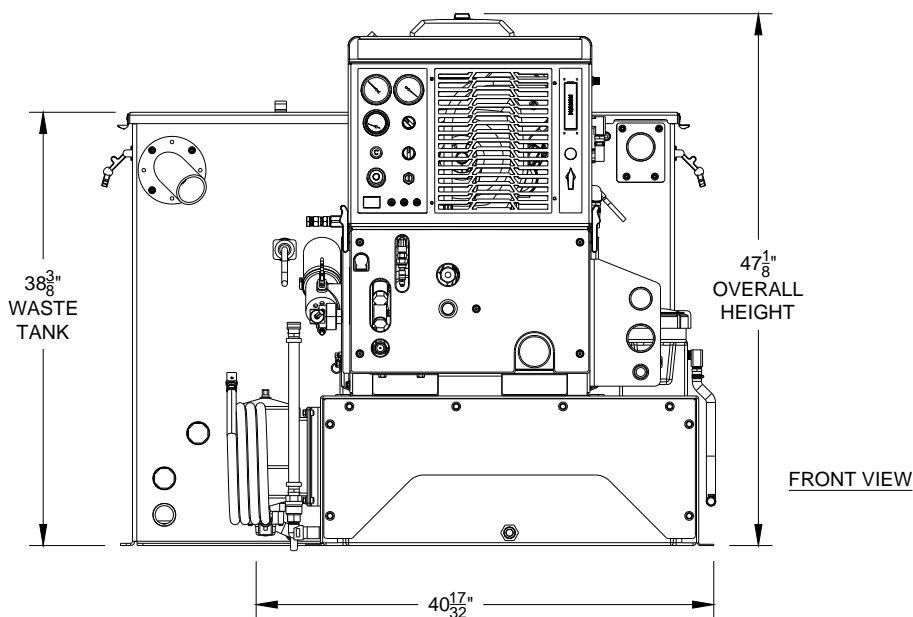
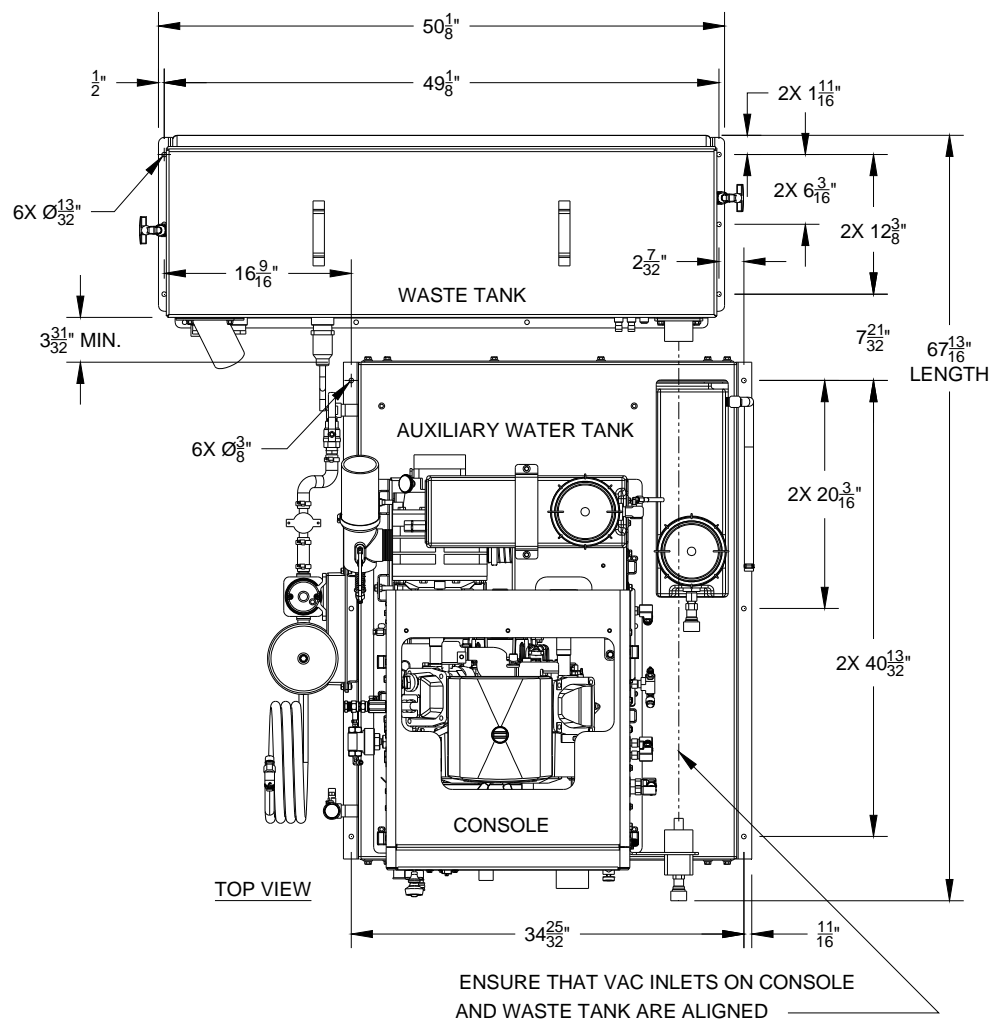

Waste Tank To Console Connection

NOTE: Before connecting any hoses to the waste tanks, make certain the hose clamps are on each hose.

1. Connect the section of 2-7/8" I.D. internal vac hose between the 2-7/8" dia. vac outlet tube on the waste tank and the vacuum pump relief valve on the console. It may be necessary to cut this hose to fit. Tighten the hose clamps.
2. Connect the 2" I.D. waste removal hose to the 2" dia. tube at the bottom corner of the waste tank. Cut to desired length. Install brass ball valve on other end.
3. Connect 2-1/2" I.D. hose between waste tank vacuum inlet (upper right of waste tank) and vacuum inlet on lower side panel of console.
4. Connect the 3/16" blue hose from the water box to the lower flare fitting (angled downward) on the waste tank.
5. Run the 5/8" water box overflow hose through the van floor. Prior to drilling through the van floor, ensure that no damage will occur in drilling area. Ensure that you are in compliance with all local environmental laws.
6. Connect the console engine shut-off cord to the waste tank level sensor cord.
7. Connect the 3/16" blue hose from the solution temperature control valve to the other flare fitting (angled downward) on the waste tank.

Fire Extinguisher

We recommend that a fire extinguisher, preferably rated for A, B, & C type fires, be installed inside the vehicle.

Fuel Pump Assembly Installation

! WARNING:

Before drilling the fuel line holes in the vehicle floor, make certain that when drilling you will not do any damage to the fuel tank(s), fuel lines, brake lines, heat shields, or any other vital component which might affect the operation or safety of the vehicle.

! AVERTISSEMENT:

Avant de percer les trous de ligne de carburant dans le plancher du véhicule, assurez-vous que lorsque vous percez vous ne serez pas faire des dommages au réservoir de carburant (s), les conduites de carburant, les conduites de frein, boucliers thermiques, ou tout autre élément essentiel qui affectent le fonctionnement ou la sécurité du véhicule.

! WARNING:

Do not mount this assembly, any hoses or components near the catalytic converter, exhaust, or any areas of high temperature. Avoid any contact with moving parts, areas of high temperature, brake lines, fuel lines, muffler, catalytic converter, or sharp objects.

! AVERTISSEMENT:

Ne pas monter cet ensemble, les flexibles ou les composants à proximité du convertisseur catalytique, de l'échappement ou de toute zone où la température est élevée. Éviter tout contact avec les pièces mobiles, les zones à température élevée, les conduites de frein, les conduits de carburant, le silencieux, le convertisseur catalytique ou les objets tranchants.

1. Determine the position where the fuel pump assembly will be mounted. Check to ensure that the power cord length will support the mounting location. The pump should be mounted as low as possible and still be protected by the frame from road hazards. **Mount the fuel pump with the discharge side of the pump higher than the suction side to eliminate the possibility of trapped air in the pump.** Additional mounting holes are provided to allow for different mounting options.
2. Drill a 5/8" (.625) diameter hole in the vehicle floor for routing the fuel pump power cord to the truck-mount console. Check to ensure that the cord length will support the location of the hole.
3. Route the power cord and install the hole grommet.
4. Do not connect the power cord to the truckmount console wiring harness until installation is complete.

Van Bulkhead Installation

1. Select a location on the vehicle floor to drill the hole for the bulkhead adapter. This location should be situated in a position that eliminates the possibility of fuel line contact by either the operator(s) or accessories during the working hours or maintenance periods. Make certain that the supplied hoses will reach the location and work with the configuration you choose.
2. Drill a 5/8" (.625) diameter hole through the vehicle floor at the installation point chosen for the bulkhead.
3. Install the 1/8 NPT bulkhead adapter by inserting the adapter and tightening the nut on the opposite side of the van floor.
4. Attach the 1/8 NPT x 1/4 Hosebarb 90 degree elbow to the bulkhead inside the van to connect the fuel system to the console.
5. Attach the 1/4" fuel hose from the console to the 1/4" Hosebarb 90 degree elbow on the bulkhead.

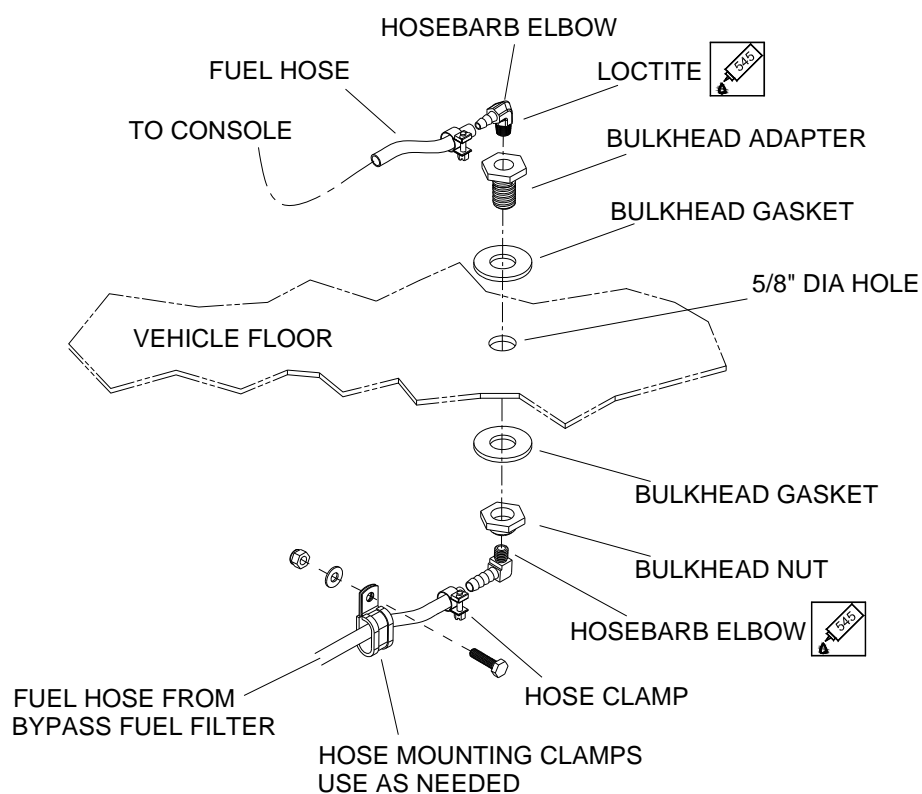

Fuel Supply & Return Line Installation (Underneath Van)

1. Attach the 1/8 NPT x 5/16 Hosebarb 90 degree elbow to the bulkhead adapter underneath the van to be used for the fuel supply line.
2. Cut to length the 6' piece of 5/16" 50 PSI fuel hose used for the supply line from:
 - a. Bulkhead adapter to the outlet side of the bypass fuel filter.
 - b. Inlet side of the bypass fuel filter to the discharge side of the fuel pump.
 - c. Inlet side of the fuel pump to the outlet side of the inline fuel filter.
3. Cut to length the 6' piece of 1/4" fuel line to connect the bypass fuel filter with the fuel tank return using the appropriate fuel tap kit.
4. Check all hose clamps for tightness.

NOTE: Fuel tap kit installation instructions are found with appropriate fuel tap kit. Refer to Fuel Tap Kit Information Sheet (8.634-994.0)

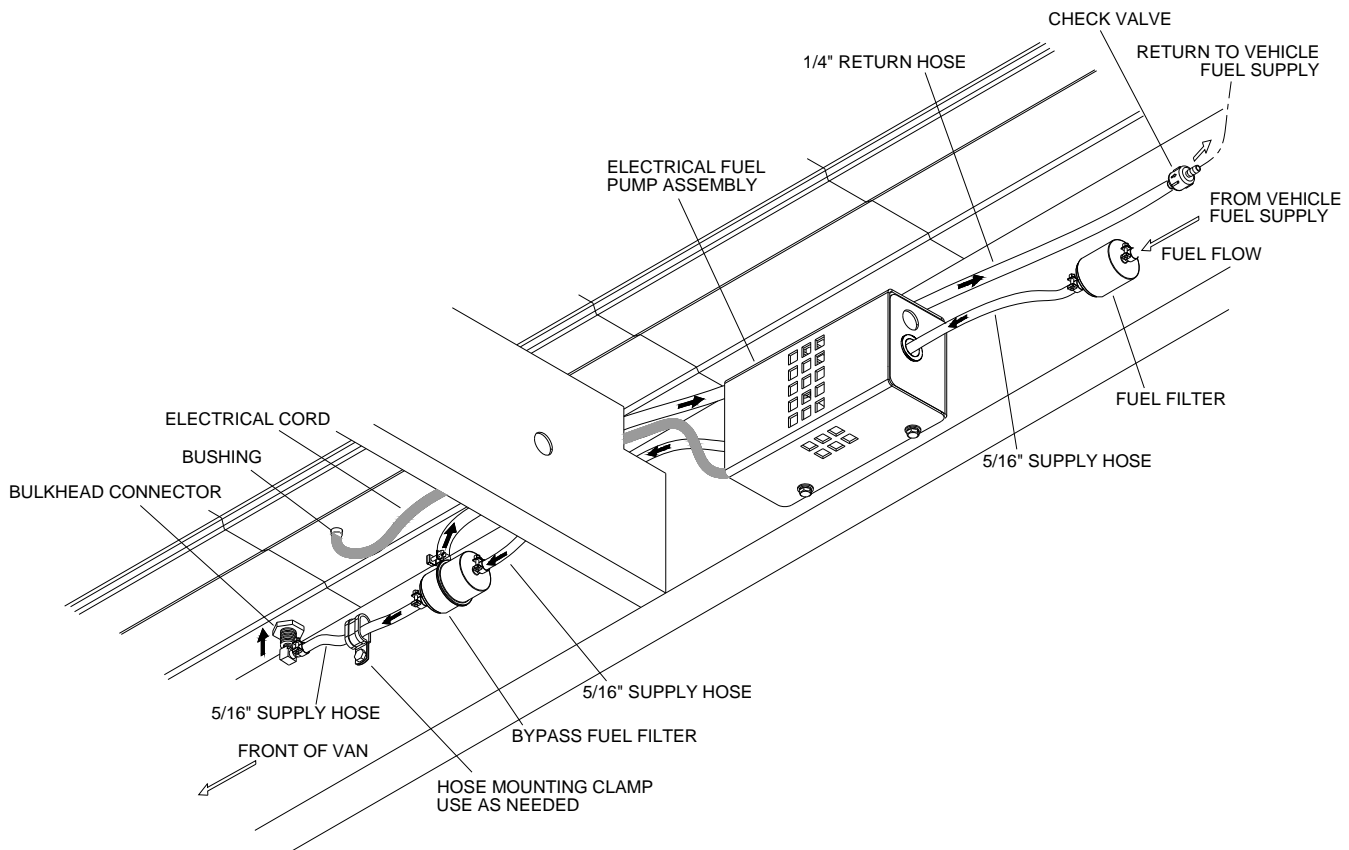

Battery Connection

! WARNING:

Dangerous Acid, Explosive Gases! Batteries contain sulfuric acid. To prevent acid burns, avoid contact with skin, eyes, and clothing.

Batteries produce explosive hydrogen gas while being charged. To prevent a fire or explosion, charge batteries only in well-ventilated areas. Keep sparks, open flames, and other sources of ignition away from the battery at all times. Keep batteries out of the reach of children. Remove all jewelry when servicing batteries.

Before disconnecting the negative (-) ground cable, make sure all switches are OFF. If ON, a spark will occur at the ground cable terminal which could cause an explosion if hydrogen gas or gasoline vapors are present. When disconnecting the battery, ALWAYS disconnect the negative (-) terminal FIRST.

! AVERTISSEMENT:

Acides dangereux, gaz explosifs! Les batteries contiennent de l'acide sulfurique. Pour prévenir les brûlures par acides, éviter tout contact avec la peau, les yeux et les vêtements.

Les batteries produisent du gaz hydrogène explosif pendant la charge. Pour empêcher tout incendie ou toute explosion, charger les batteries uniquement dans des endroits bien ventilés. Garder la batterie à l'écart des étincelles, de la flamme nue et de toute autre source d'inflammation en tout temps. Garder les batteries hors de la portée des enfants. Enlever tous les bijoux au moment de procéder à l'entretien des batteries.

Avant de débrancher le câble de terre négatif (-), s'assurer que tous les commutateurs se trouvent ne position OFF (arrêt). S'ils se trouvent en position ON (Marche), une étincelle au niveau de la borne du câble de terre pourrait causer une explosion si du gaz hydrogène ou des vapeurs d'essence sont présents. Au moment de déconnecter la batterie, TOUJOURS déconnecter d'ABORD la borne négative (-).

1. Attach the red positive (+) battery cable from the console starter solenoid to the positive (+) terminal on the battery and tighten the holding nut.
2. Next, attach the black negative (-) battery cable from the console ground to the negative (-) terminal on the battery and tighten the holding nut.

BATTERY HOOK-UP

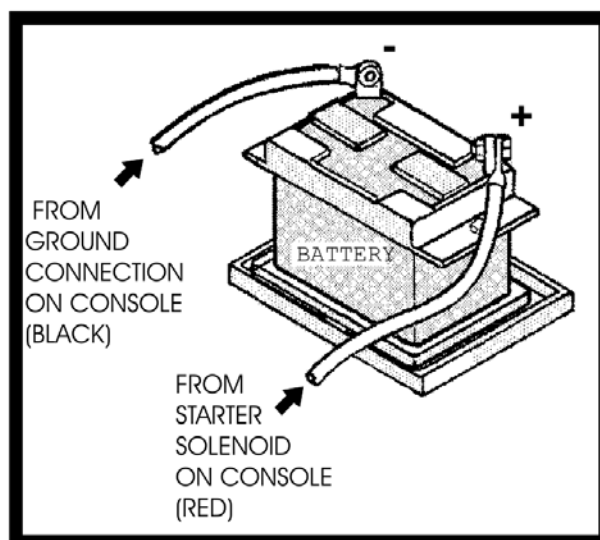

Initial Operational Settings

NOTE: Due to temperature and altitude changes, the optimal settings for each truckmount must be adjusted after installation. Failure to make these adjustments may lead to poor unit performance and premature component failure.

Vacuum Pump

The maximum vacuum pressure obtainable at full throttle should be 13"Hg. If the unit is drawing a stronger vacuum (at full sealed suction) than 13" Hg, adjust the vacuum relief spring to 13" Hg.

Engine

Set RPM Values as shown below. Refer to Engine Operation Manual for adjustment instructions.

THROTTLE	LOAD	RPM*
Idle	None	1400 rpm
Full	13" Hg. Vacuum 500 psi pressure	2850 rpm
Full	None	2950 rpm

*±50 rpm tolerance

Technical Specifications

ITEM	DIMENSION/CAPACITY
Engine speed	2950 rpm 1400 rpm (idle speed)
Water pump rpm	1680 rpm
Vacuum pump rpm	3385 rpm
Water flow rate	3.5 GPM (maximum)
Solution pump pressure	1200 PSI (maximum)
Vacuum relief valve	13" Hg
Waste tank capacity	60 gallons / 100 gallons
Console weight	600 lbs. (690 lbs. If mounted on water tank)
Console weight with: 60 gallon waste tank & accessories	810 lbs. with empty waste tank 1252 lbs. with full waste tank
Console weight with: 60 gallon waste tank, water tank & accessories	900 lbs. with empty waste and water tanks 1342 lbs. with full waste tank, and empty water tank 1842 lbs. with full waste and water tanks
Console weight with: 100 gallon waste tank & accessories	820 lbs. with empty waste tank 1445 lbs. with full waste tank
Console weight with: 100 gallon waste tank, water tank & accessories	910 lbs. with empty waste tank 1535 lbs. with full waste tank, and empty water tank 2035 lbs. with full waste and water tanks
TORQUE VALUES	
Engine rear / vac pump pulley	16 foot lbs
Engine front / water pump pulley	9 foot lbs

Fuel Requirements

Use **unleaded gasoline ONLY**. **DO NOT** use any gasoline additives. We recommend the use of clean, fresh, unleaded gasoline intended for automotive use. High octane gasoline should **NOT** be used with the engine on this unit. These engines are NOT designed to use E-85 or Flex Fuels.

Engine Oil Requirements

Use high quality detergent 10W-30 oil of at least API (American Petroleum Institute) service class SG, SH, SJ or higher.

NOTE: Using a lower service class oil or extending oil change intervals longer than recommended can cause engine damage.

NOTE: Synthetic oils meeting the listed classifications may be used with oil changes performed at recommended intervals. However to allow piston rings to properly seat, a new or rebuilt engine should be operated for at least 50 hours using standard petroleum based oil before switching to synthetic oil.

Altitude Requirements

Engines perform differently with increases/decreases in altitude. Be sure to check engine speeds during initial installation. See engine speeds in Technical Specifications section.

NOTE: To ensure correct engine operation at altitudes above 1525 meters (5000 ft.), it may be necessary to have an authorized dealer install a special high altitude jet kit in the carburetor. If a high altitude kit has been installed, the engine must be reconverted to the original jet size, before it is operated at lower altitudes, or overheating and engine damage can result.

Chemical Requirements

This cleaning unit, due to its chemical injection pump design, can be used with a variety of water-diluted chemical compounds (either acidic or alkaline), depending on the job to be done. However, to obtain optimum results with this unit, we recommend using the PROCHEM line of chemicals. For information on using the cleaning compounds, refer to the chemical manual.

Water Requirements

Hard water deposits will adversely affect the plumbing and heat exchange systems on this unit. The map below will give you an idea of where areas of high water hardness may occur. However, any water supply obtained from a well is almost always hard water and a water softener will be needed to protect your equipment.

NOTE: Equipment malfunction or component failure caused by hard water scaling is NOT covered under the warranty.

If you are operating this unit in an area where the unit will be using water in which the hardness exceeds 3-1/2 grains, we highly recommend a suitable water softener be installed. If using a water softener, it must have a five (5) GPM (or greater) flow capacity without any hose constrictions.

Using a water softener will reduce maintenance and decrease down time caused by hard water scaling. It will also allow cleaning chemicals to be more effective in lower concentrations.

If you require a water softener, your dealer has a model to meet your needs. Please contact your nearest distributor for information, price, and availability.

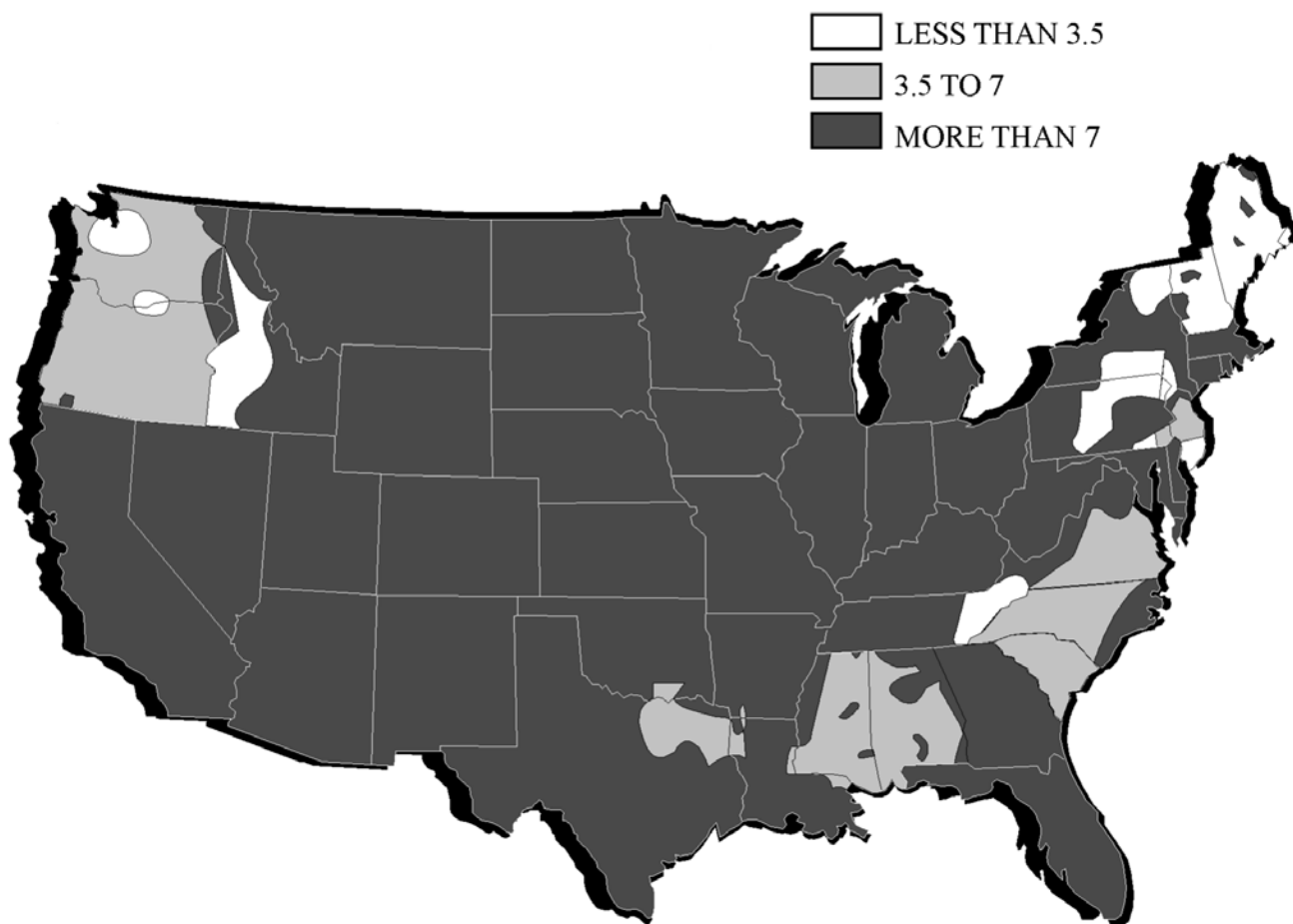

Components

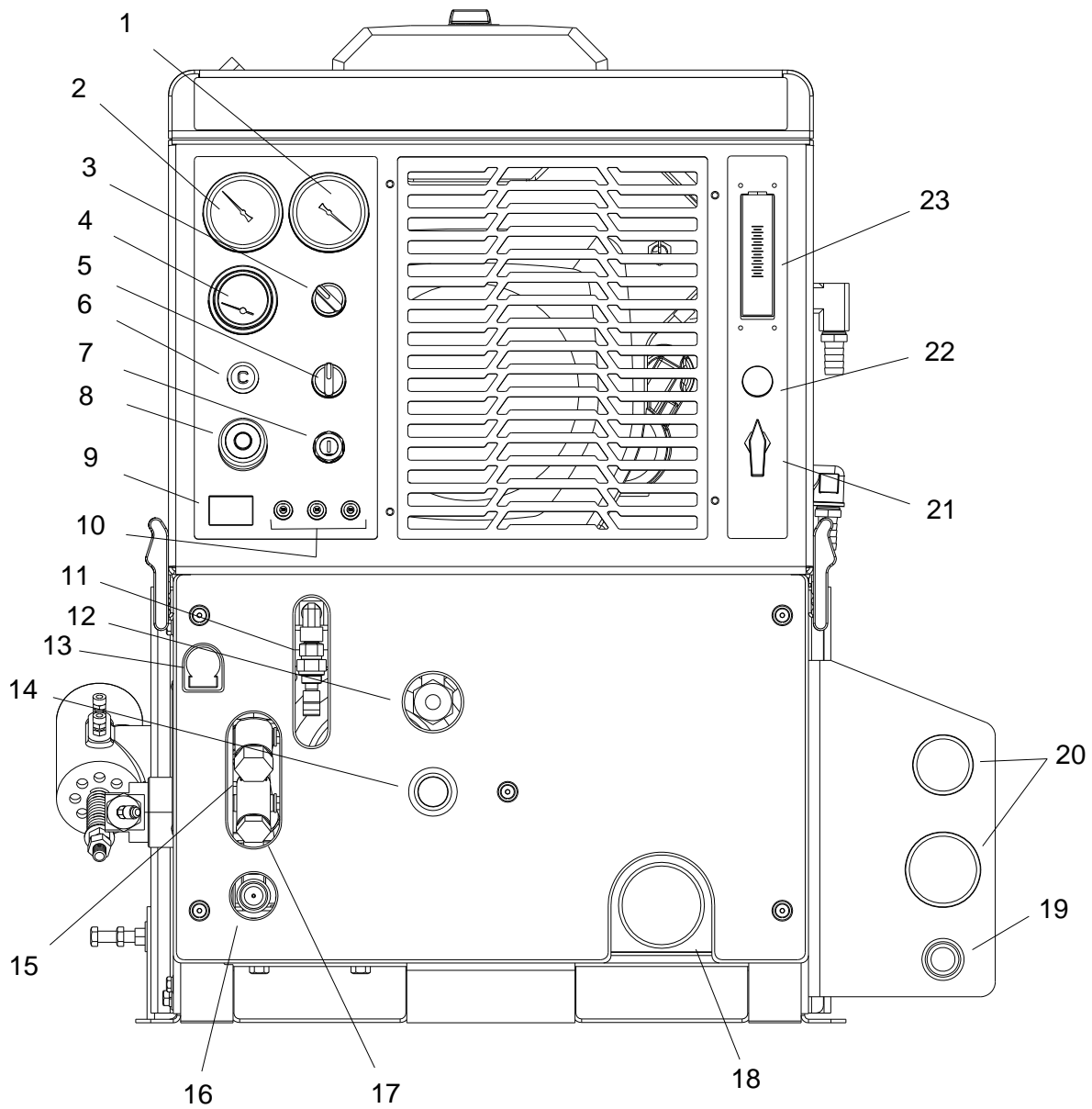

Components

1. Vacuum Gauge

This gauge indicates in inches of mercury how much vacuum the system is producing at any given time.

2. Solution Pressure Gauge

This gauge registers the amount of pressure in the system.

3. Waste Pumpout

This switch actuates the optional waste pumpout.

4. Solution Temp Gauge

This gauge measures the temperature of the cleaning solution exiting the machine.

5. Solution Pump Switch

This switch serves to energize the magnetic clutch, to turn the pump on and off. Turn clockwise to activate the pump and counter clockwise for deactivating the pump.

6. Choke

The choke is for restricting air to the carburetor, this enriches the fuel mixture. The primary purpose is for starting in cold temperatures. When the cable is pulled out air is restricted, when pushed in the engine is in run position.

CAUTION:

Do NOT run engine with choke pulled out.

ATTENTION:

Ne pas faire fonctionner le moteur avec l'étrangleur en position tirée.

7. Ignition Switch

The ignition switch controls the power for the machine. To turn the machine on, turn solution pump switch counterclockwise to override and hold. Turn key clockwise until engine starts and release. Wait 5 seconds then release override switch. To stop engine rotate key to OFF position.

8. Throttle

The throttle is used to set the speed of the engine (rpm). The engine speed (rpm) may be increased by releasing the collar lock, pushing in the red button on the end of the handle, and pulling the handle straight out. Engine speed may be changed in smaller increments by rotating the throttle handle clockwise or counter-clockwise. The collar lock can be tightened to prevent the throttle from slipping and changing the engine speed.

9. Hour Meter

The hour meter records the number of hours the unit has run. This serves as a time recorder for servicing the machine.

10. Circuit Breakers

These serve to protect the circuits from electrical spikes and over loads and protects wires from damage and fire.

11. Temperature Balance Orifice

The temperature balance orifice helps to balance and stabilize the solution temperature within the system.

12. Solution Pressure Regulator

The pressure regulator sets the pressure of the solution system. This spring loaded valve can be adjusted up or down. The pressure is increased by turning the valve clockwise, or reduced by turning the valve counter clockwise. (This valve must be maintained in accordance with this manual's maintenance table.)

13. Lubrication Cup

The lubrication cup allows lubricant spray to reach the vacuum blower.

14. Solution Temperature Control Valve

This valve allows the operator to control the solution temperature by bypassing hot water to the waste tank, for low temperature cleaning such as upholstery. Turning the valve counter clockwise opens the valve. Turning clockwise closes the valve and has the effect of stopping water from bypassing.

15. Chemical Check Valve

The chemical check valve allows chemicals to enter the system and travel in a singular direction to the wand. The chemical check valve prevents chemicals from traveling upstream into the solution system of the unit.

16. Solution Outlet

The solution outlet is the connecting point for the high pressure solution hoses. This outlet is a quick disconnect that allows hoses to be plugged into the unit.

17. Solution Screen

The solution screen is located on the front of the machine. The function of this screen is to trap foreign particles from exiting the machine and plugging the orifices of the cleaning tools. This screen is part of the machine maintenance cleaning.

18. Exhaust

Exhaust fumes contain carbon monoxide which is an odorless and deadly poison that can cause severe injury or fatality. DO NOT run this unit in an enclosed area. DO NOT operate this unit where the exhaust may enter any building doorway, window, vent, or opening of any type.

19. Water Inlet

This quick connect allows the water supply hose to be connected to the unit.

20. Vacuum Inlets

The vacuum inlets serve as connecting points for vacuum hoses.

21. Chemical Prime Control Valve

This valve allows the chemical to circulate through the chemical system with little or no restriction. It also purges out air that may be trapped in the lines and cavities of the chemical pump. By turning the valve clockwise the injection system is enabled.

22. Chemical Metering Valve

The chemical metering valve regulates the amount of chemical that is injected into the system. Clockwise rotation of the knob closes the valve. Counter clockwise rotation opens the valve, allowing more chemical to enter the system.

23. Flow Meter

The flow meter is a gauge to indicate how much liquid chemical is being introduced in the water system. The quantity can be increased by turning the chemical flow knob counter clockwise.

Vacuum System

The engine turning the vacuum pump generates vacuum. The air is channeled in one side of the vacuum pump, compressed and discharged on the opposite side, creating airflow.

The movement of air is used to do the work necessary for the extraction process. A vacuum nozzle applied to the carpet surface removes moisture, dirt and spent chemicals. These elements are conveyed back to a separating tank utilizing hoses and the force of air. Particles of moisture and dirt are separated in the vacuum tank using a series of changes in direction and velocity. The air is then filtered and rushes into the vacuum pump.

The vacuum pump compresses and heats the incoming air. The hot discharged air is forced down stream into a silencer for noise abatement. After exiting the silencer, this hot air is mixed with hot air exhaust gases from the engine. This mixture of hot air and gases are then forced through 3 radiators serving as heat collectors. Heat from the engine and vacuum pump is then transferred into the plumbing system raising the water temperature for better cleaning.

The vacuum pump speed is factory set to maximize vacuum pressure and provide sustained system life. Do not alter the vacuum speed outside the recommended range shown in the Technical Specifications section.

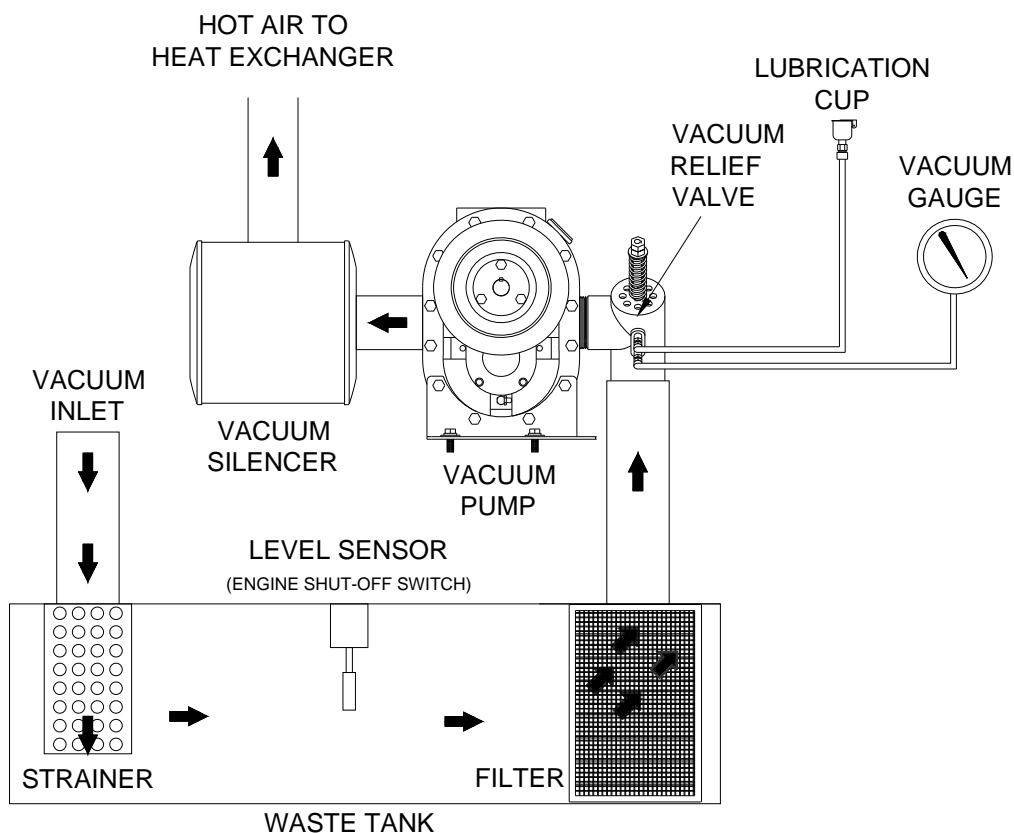

! WARNING:

Always wear hearing protection and proper personal protection equipment when operating unit.

! AVERTISSEMENT:

Toujours porter une protection de l'ouïe durant le fonctionnement de l'appareil. Toujours se conformer à l'ordonnance locale sur la protection contre le bruit lors de l'utilisation d'appareils.

Water Pumping and Heat Transfer System

Cold water enters the console through the water inlet. When the water box is full the valve will automatically shut off.

Water then flows from the water box, through the strainer, into the solution pump. The water is pumped to the pressure regulator manifold, which provides and maintains the desired pressure setting.

The pressure regulator manifold includes a pulse hose, which helps reduce pressure spikes from the pump.

A certain amount of water is by-passed from the pressure regulator due to over pumping capacity of the solution pump. Water that is not called for in the cleaning process is channeled through a copper heater core in the front of the heat exchanger box. This bypass water circulates several times through the heater core pre-warming the water.

The gases coming from the vacuum pump and the engine exhaust are forced through the middle and rear heater core creating the hottest area of the heat exchanger box, and increasing the heat transfer to the circulating water.

The hot water passes to the solution outlet manifold where cleaning chemicals are injected from the chemical pulse pump. This manifold serves as a connecting point for the high-pressure hoses. Also a check valve is located in this outlet manifold prohibiting chemicals from backing up into the system.

The cleaning solution then passes through high-pressure solution hoses and is distributed by the cleaning tool to a surface that is being cleaned, completing the water pumping and heating cycle of the cleaning unit.

Heat Exchanger

The water temperature in the plumbing system is raised for better cleaning. This happens in the heat exchanger. The heat exchanger is made up of three stages. These three stages are engine exhaust stage, the mixing stage, and the pre-warming stage.

The angled rear heat exchanger core receives its heat only from the engine exhaust gases. This core becomes extremely hot and should not be touched while the machine is in operation. Allow the machine to cool down completely before attempting to service this area.

The middle core receives its heat from the mixing of both the engine exhaust and the vacuum pump exhaust. The vacuum pump heats incoming air as it is compressed. This hot air is mixed with the hot engine exhaust gases exiting the angled rear core. This mixture of hot air and gases is then forced through the middle core and on through the front heat exchanger core.

The front core continues to extract heat from the mixed gases; but, this heat is used to pre-heat the water box as a preliminary hot water reservoir.

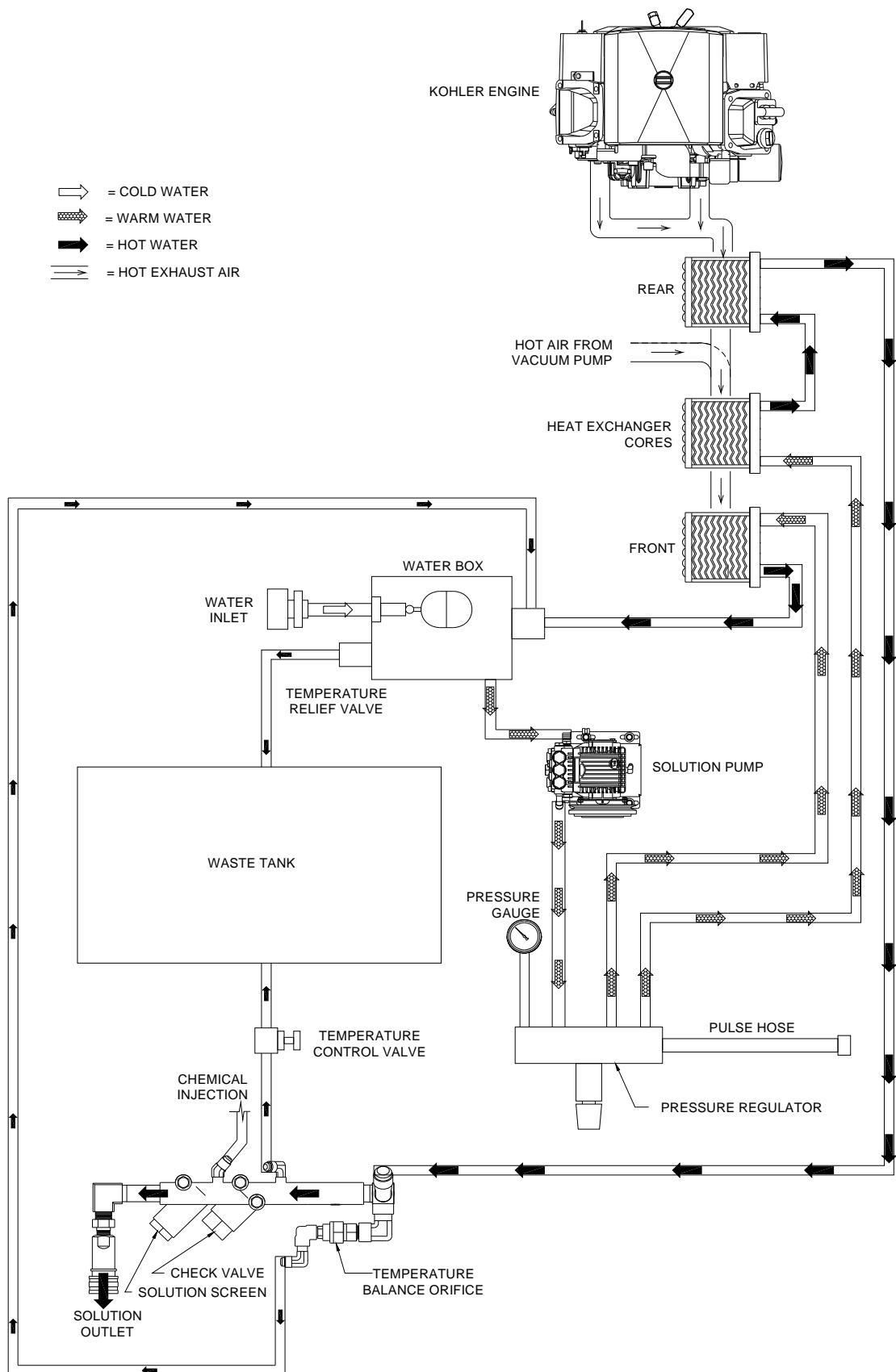

Chemical Injection System

The chemical injection system is unique in that it utilizes the pressure spikes generated by the high pressure solution pump to move chemical into the main solution stream. The high pressure spikes move the diaphragm in the chemical pulse pump forcing small amounts of liquid chemical to be moved in a single direction of flow with the aid of two check valves.

The chemical is drawn from the container, and through the flow meter, which indicates rate of flow. The chemical then moves to the chemical pulse pump where it is pressurized.

The chemicals flow to the chemical selector valve, which can turn off the chemical flow or when set to "Prime" sends it into a bypass loop to purge air from the system, or when "CHEM" the chemical can be directed to the metering valve. The metering valve controls the amount of chemical that enters the solution outlet manifold.

The manifold assembly's check valve will not allow the chemicals to travel upstream into the plumbing system of the unit. The chemicals are mixed there with hot pressurized water that makes a cleaning solution. The solution then flows to the outlets for cleaning.

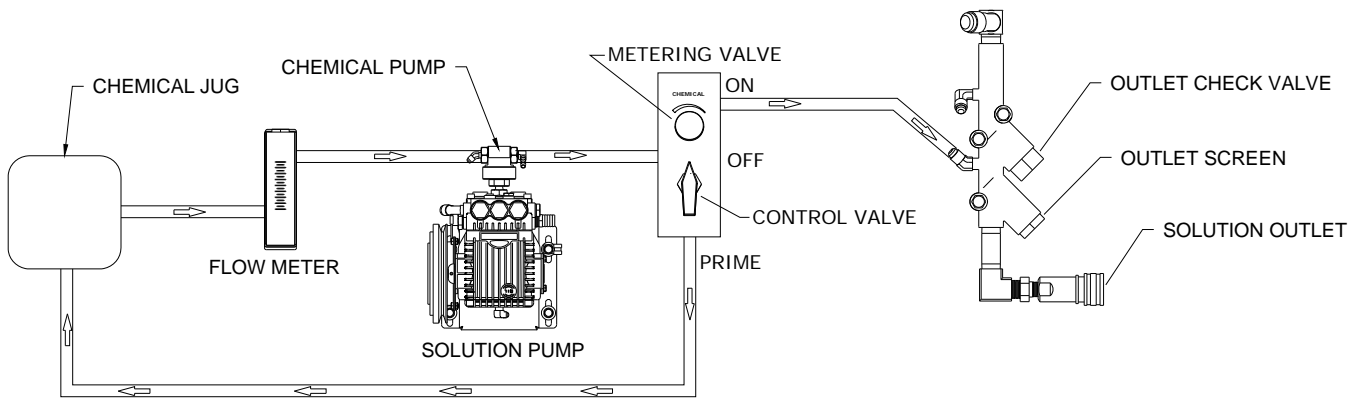

Pre-Run Inspection / Setup

NOTE: Operation of this unit is simple. However, only trained personnel should proceed.

! WARNING:

Operate this unit and equipment only in a well-ventilated area. Exhaust fumes contain carbon monoxide, which is an odorless and deadly poison that can cause severe injury or fatality. **DO NOT** operate this unit where the exhaust may enter any building doorway, window, vent, or opening of any type.

! AVERTISSEMENT:

Utiliser cet appareil et l'équipement uniquement dans un endroit bien ventilé. Les gaz d'échappement contiennent du monoxyde de carbone qui est un gaz inodore et mortel pouvant causer des blessures graves ou entraîner la mort. **NE PAS** utiliser cet appareil dans un endroit où les gaz d'échappement risquent de pénétrer dans une entrée de porte, une fenêtre, un évent ou toute ouverture d'un édifice.

Check For Adequate Fuel

Check the fuel tank to be certain there is adequate fuel to complete the job. This unit uses approximately .75 – 1.00 gallons of fuel per hour, depending on the speed setting.

Remove Tools From Vehicle

Remove any tools or hoses from the van, which you will require.

Water Supply Connection

NOTE: Before connecting your water hose to the supply faucet, flush out the faucet until the water is free of any debris. Flush out any debris which may be in your water inlet hose.

1. Connect the water supply hose to the water inlet quick-connect on the right side panel of the console. Connect the hose to the water supply faucet.

NOTE: Never use your waste pump outlet hose as a water inlet hose. Use only clean hoses for water inlet.

2. Turn the water supply faucet on. The water will fill the water box.

! WARNING:

Don't run the solution pump dry, damage may occur and void the warranty.

In the event the pump is run dry, allow the pump to cool down to ambient temperature before reintroducing water. Otherwise major damage may occur and void the warranty.

! AVERTISSEMENT:

Ne pas laisser la pompe à solution fonctionner à sec, cela risquerait d'entraîner des dommages et d'annuler la garantie.

Si la pompe venait qu'à fonctionner à sec, laisser refroidir la pompe à température ambiante avant de réintroduire de l'eau. Sinon, cela risquerait d'entraîner des dommages et d'annuler la garantie.

High Pressure Solution Hose

Before starting the unit, connect the high pressure solution hose to the outlet connection at the front of the unit. Connect the cleaning tool to the pressure hose.

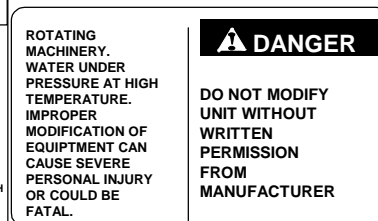
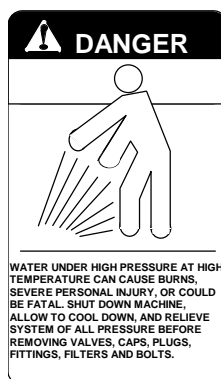

Vacuum Hose

Connect the vacuum hose to the vacuum inlet connection at the front of the unit. Connect the other end of the vacuum hose to the cleaning tool.

Filters

Ensure all filters on machine and in waste tank are free of debris.

Priming the Chemical Pump

1. Fill chemical container and inspect chemical strainer.
2. Insert chemical inlet and prime tubing into chemical container.
3. Pull out engine choke, turn solution pump switch to override and turn ignition key to start.
4. Push in engine choke after engine has started.
5. Set throttle to idle position.
6. Turn on solution pump.
7. Turn chemical control valve to prime and allow chemical to circulate. After all air bubbles have been removed from chemical tubing, turn the valve to the horizontal (off) position.
8. Turn the chemical control valve to run. use the chemical metering valve to set the chemical flow to the desired flow rate while observing the flow meter indicator. To accurately set the chemical flow, pull the trigger on the cleaning tool while adjusting the flow rate.
9. Set throttle to maximum position for quick unit heat up.

NOTE: Do not run the machine with the port blocked for more than 2 minutes to avoid overheating.

Once you have completed priming the chemical pump, proceed with the cleaning operation. Your unit should be in the correct throttle position for your cleaning operation or extracting.

WARNING:

Always dispose of waste in accordance with Local, State, and Federal laws.

AVERTISSEMENT:

Toujours éliminer les résidus conformément aux lois locales, provinciales et fédérales.

Waste Pump (Optional)

1. If your unit is equipped with an automatic waste pump, connect one end of a garden hose to the pump-out connection and the other end to an appropriate waste disposal.
2. Turn the pump-out switch on the control panel to the ON position. The waste pump will operate automatically throughout the cleaning operation.

We recommend that you use a 3/4" I.D. water hose as a waste pump outlet hose. DO NOT use a hose smaller than 5/8" I.D.

NEVER use your automatic waste pump outlet hose as a water inlet hose.

Cleaning

Observe the following guidelines, while cleaning:

1. Before proceeding make sure the spray tips are functioning properly.
 - a. To check, hold the wand about one foot above the surface to be cleaned and open the wand valve. A full spray should be observed from all of the spray tips.
 - b. If the spray tips are not showing a full spray pattern, adjust for proper pattern, clean, or replace spray tips, if required.
2. Normally chemical is applied on the push stroke of the wand when cleaning and vacuuming is done on the pull stroke. For heavily soiled carpets the wand may be used in a scrubbing manner, applying chemical in both push and pull strokes. Always finish up an area with a vacuum stroke.
3. When cleaning, keep the working opening (mouth) flat on the surface being cleaned. Keep the wand moving when the valve is open.
4. The unit will automatically shut-down when the waste tank is full. This will prevent water being drawn into the vacuum pump. If shut-down occurs, empty the waste tank before proceeding. If shut-down occurs due to foam created by chemicals used, add Prochem defoamer.

Upholstery Cleaning

Upholstery tool, (See Options Section)

1. To protect fabrics, reduce solution temperature as needed by opening the solution temperature control valve on the lower front panel. Engine speed may also be reduced slightly to reduce heat and vacuum.

Shutdown and Daily Maintenance

1. Close chemical metering valve.
2. Allow the unit to run for 2 minutes with the vacuum hose disconnected to remove moisture. Spray water displacing lubricant into the vacuum lubrication cup. This will prevent corrosion due to moisture.
3. Set engine throttle at idle position and allow the water temperature to cool down, utilizing the temperature control valve in the open position to bleed off residual hot water left in the system.
4. Close temperature control valve and turn off ignition switch.
5. Disconnect all hoses and tools.
6. Drain waste tank and rinse with clean water.

De-Flooding Operations

De-flooding operations involve removal of water from carpet and flooring. This differs from normal cleaning operations in that no water or solution is required. An automatic waste pump-out is highly recommended for all de-flooding operations due to the large amount of water removal often required.

1. Start unit.
2. Set pressure regulator at 100 psi.
3. Shut off solution pump.
4. Begin de-flooding operations.
5. Under almost all conditions, the unit will sufficiently cool itself. If you find yourself operating in extreme heat: Hook up a water supply; turn on the water pump at 100 psi, and crack the temperature control valve slightly to provide additional cooling to the solution system.

Freezing Protection

CAUTION:

If the unit is exposed to freezing weather the water in the unit may freeze, causing **SERIOUS DAMAGE** to the unit. To avoid this, the following is recommended during the cold weather season.

ATTENTION:

Si l'appareil est exposé au gel, l'eau dans l'appareil risque de geler, causant ainsi des **DOMMAGES MAJEURS** à l'appareil. Pour éviter une telle situation, il est recommandé de faire ce qui suit durant la saison froide.

When the unit is not in use, always park it in a heated building.

While in operation, avoid long shutdowns as the unit provides heat while running. Shut it down just prior to leaving for the next job.

If a heated building is not available, we recommend that you winterize the unit with anti-freeze. At present, it is only possible to winterize units, which do not have an auxiliary water tank. Units with auxiliary water tanks must be stored in a heated building when not in use.

Overheating Protection

Air cooled engines rely on the flow of air over the engine for cooling operations. Ensure that there is sufficient air flow in the van. **Never** operate the unit with all the vehicle doors closed and no alternative ventilation system.

This unit must be operated with the vehicle or trailer doors open in order to ensure adequate engine ventilation.

Winterizing the Unit

1. Shut off the water supply. Disconnect the water inlet hose from the front of your console.
2. Connect all high pressure solution hoses and tools that may have water in them.
3. Start the unit and turn solution pump on. Open the tool valve until water pressure drops.
4. Turn off solution pump. Fill the water box with approximately two gallons of 100% glycol base anti-freeze.
5. Turn the solution pump switch ON.
6. Open the tool valve until anti-freeze begins to come out of the tool. Recover ALL anti-freeze that comes out of the tools into an approved container. We strongly recommend that you re-cycle and re-use the anti-freeze.

Repeat this procedure with all the remaining tools. After all tools and pressure hoses have been filled with anti-freeze, disconnect and store them.

7. Turn the solution pump switch OFF. Attach the winterizing loop hose with attachment, Part #86260700, to the solution outlet connection and the water inlet connection. Turn the solution pump switch ON.

Allow the unit to run for approximately 3 minutes with the winterizing loop hose attached.

8. Open temperature control valve and allow anti-freeze to flow to waste tank.

9. Prime the chemical system with 50/50 anti-freeze/water mix. Insert the chemical inlet and prime discharge tubes into the anti-freeze container. Turn the chemical valve to PRIME until anti-freeze begins to flow out of the prime hose.
10. Turn the chemical valve to the open position, making certain that the flow meter indicates flow and that all anti-freeze drains out of the chemical hose into an approved container, after 30 seconds, turn off both valves.

Removing Anti-Freeze From the Unit

1. Connect the water inlet hose to the water inlet connection on the console. Turn the water supply on.
2. Start unit turn on pump.
3. Connect all solution hoses and any tools which require purging of anti-freeze to the solution outlet connection(s).
4. Open the tool valves and drain the anti-freeze into an approved container until the flow is clear and all anti-freeze is purged from the tools and hoses.
5. Place the chemical prime hose into the approved container. Submerge the chemical inlet hose in water. Turn the chemical valve to the PRIME position until clear water comes through the prime hose, and then remove the prime hose from the container.
6. Turn the chemical valve to the ON (CHEMICAL) position. This will allow water to flow into the other side of the system.

Once all of the anti-freeze is removed, the unit is ready to use.

Eventually, the anti-freeze in your storage container will become diluted with water. If the anti-freeze level drops below 50% of the total, dispose of it and start with fresh 100% anti-freeze.

WARNING:

When disposing of used anti-freeze, observe local laws and regulations. Do not drain onto the ground or into storm drainage systems.

AVERTISSEMENT:

Lors de l'élimination de l'antigel usé, respecter toutes les lois et tous les règlements locaux. Ne pas vider sur le sol ou dans des réseaux de collecte des eaux pluviales.

Service Schedule

Engine	Daily	Check engine oil level. *** Fill to proper level (Do not overfill)
Vacuum Pump	Daily	Spray water displacing lubricant in lubrication cup at front of console for 5 sec.
Solution Pump	Daily	Check oil level.** Fill to proper level (Do not overfill)
Chemical Inlet Tube Strainer	Daily	Check strainer for blockage, remove any debris
Vacuum Inlet Filter (In Waste Tank)	Daily	Clean filter, inspect, replace if damaged
Vacuum Hoses	Daily	Wash out with clean water
Automatic Waste Pump	Daily	Inspect and remove any debris or sediment
Vacuum Pump	Weekly*	Check oil level. Fill to proper level
Water Box Float Valve	Weekly	Check for proper seating and shut-off
Solution Pump Inlet Strainer	Weekly*	Check for debris and clean
Temperature Balance Orifice	Weekly	Remove, clean and check screen (as needed)
Battery	Weekly*	Check for proper fluid level. Fill with distilled water only
Solution Outlet Screen	Weekly*	Inspect and remove any debris or blockage
High Pressure Hoses	25 hrs	Inspect for damage or impending damage
Pressure Regulator	50 hrs	Lubricate o-rings
Pressure Regulator	50 hrs	Lubricate plug behind spring
Engine	100 hrs	Change engine oil and oil filter***
Battery	100 hrs*	Clean battery terminals
Automatic Waste Pumpout	100 hrs	Clean inlet and outlet ports
Belts/Pulleys	100 hrs	Check belt wear and tension. Check pulley alignment.
Water Box Float Valve Seal	200 hrs.	Inspect and replace seal as needed
Engine	200 hrs	Service air cleaner elements*
Fuel Pump	200 hrs	Check hose connections
Engine	200 hrs	Replace fuel filter (carbureted engines)
Engine	200 hrs	Check spark plugs for carbon deposits and proper gap
Chemical Valves	200 hrs	Inspect and/or adjust packing nuts
Temperature Control Valve	200 hrs	Inspect and/or adjust packing nuts

Vacuum pump	250 hrs	Lubricate bearing on pulley end with grease
Vacuum Exhaust Heat Exchanger	500 hrs	Inspect cores and remove debris.
Solution Pump	500 hrs	Change oil**
Pulley Set Screws & Hub Cap Screws, Solution Pump Clutch Shaft Bolts	500 hrs	Check for proper torque values. Re-torque, if required****
Drive Pulley	500 hrs	Inspect, clean and check for pulley groove wear****
Drive Pulley	500 hrs	Check pulley alignment****
Drive Belts	500 hrs	Inspect and clean****
Drive Belts	500 hrs	Check belt tension****
Chemical Pump & Check Valves	500 hrs	Replace diaphragm, plastic disk and check valves.
Vacuum Lubrication Lines	500 hrs	Check for line obstructions. Replace tubing if cracked or damaged
Engine	500 hrs	Replace in-line fuel filter on engine.
Engine	1000 hrs	Replace spark plugs.
Chemical Pump & Check Valves	1000 hrs	Replace diaphragm, plastic disk and check valves.
Check Valve (Solution Outlet)	1000 hrs	Inspect, clean, and repair, if needed.
Waste Tank Shut-off Float Switch	Monthly	Check for debris hindering movement
Vacuum pump	Yearly	Drain and replace oil*****
Waste Tank Filters/Strainers	Yearly	Check for damage and blockage. Replace if needed.
Engine	Yearly	Replace air cleaner element
Engine	3 years	Replace ignition wires.

* Or as often as required

** Change solution pump crankcase oil after the first 50 hours

***Change engine crankcase oil and filter after the first 8 hours

****Perform drive belt, pulley and hub maintenance after the first 25 hours of operation, and then again at 100 hours

*****AEON PD-XD Synthetic Lubricant - Drain and replace oil after the first 100 hours, then drain and replace oil every 1500 hours, or once a year, whichever comes first.

Key Checkpoints

NOTE: Initiation of a planned preventative maintenance program will assure that your unit has optimum performance, a long operating life, and a minimal amount of "down" time.

External Fuel Pump Maintenance

The power plant for the unit receives fuel from the main fuel tank of your van/truck. An external fuel pump that provides this fuel is located on the underside of the van/truck. Loose fittings and hose connections will cause your unit to perform poorly. Follow the recommended fuel pump maintenance in the Maintenance Schedule in this manual. Refer any additional questions to your dealer.

Chemical Supply System Maintenance

The chemical supply system pulls chemicals from your chemical bottle utilizing a pump that works off the water pump pulsing. Any clogged filters or loose connections will result in a chemical supply system malfunction or a malfunction at the cleaning tool. Maintenance of the solution outlet check valve and screen are vital to effective cleaning operation and minimal unit downtime. Additionally, the hoses related to supplying water and chemical to the outlet manifold are under high pressures and experience thermal expansion and contraction. Periodic inspections of these hoses for tears, cracks, and failing connectors are necessary to avoid unwanted leaks. To keep your chemical system functioning properly, follow the chemical pump and solution outlet maintenance in the Maintenance Schedule in this manual. Refer any additional questions to your dealer.

Heat Exchanger System Maintenance

The heat exchange system in your unit transfers energy from the engine's exhaust and blower discharge air to the solution supply system. The heat transfer of this system is highly dependent on the surface area contact in the heat exchanger cores located in the heat exchanger box. This surface area amount is adversely minimized when the supplied water is not softened to recommended levels. Hard water will result in scaling on the inside walls of the heat exchanger tubes. It is recommended that you use a manufacturer approved water softener to avoid premature heat exchanger core failure. Contact your local dealer for advice on the water hardness levels in your area.

Additionally, the heat exchanger tubes are very sensitive to freezing conditions. As the water freezes during cold conditions, it expands in the heat exchanger tubes and causes damage. Often the tubes are cracked and require the replacement of the heat exchanger core. Refer to the Freeze Protection instructions section in this manual. Refer any additional questions to your dealer.

Vacuum Pump Maintenance

(Refer to pump manufacturer's manual for specific maintenance instructions)

The total function of the unit is based around the performance of the vacuum pump. Heat transfer used to raise the temperature of the solution is gained from the air drawn by the vacuum pump and solution is removed from the carpet with the vacuum suction of the vacuum pump. General maintenance actions for the vacuum pump as listed in this manual are vital to prolonged vacuum pump operations. Daily lubrication of the pump is required to avoid seizure of the system. Also, waste tank filters and strainers must be maintained to prevent unwanted debris from entering the vacuum pump.

WARNING:

DO NOT service this unit while it is running. The high-speed mechanical parts as well as high temperature components may result in severe injury, severed limbs, or fatality.

AVERTISSEMENT:

NE PAS réparer cet appareil pendant qu'il est en marche. Les pièces mécaniques se déplaçant à haute vitesse de même que les composantes à température élevée peuvent causer des blessures graves ou des amputations.

NOTE: Use the hour meter as a guide for coordinating the maintenance schedule.

Engine

(Refer to engine manufacturer's manual for specific instructions)

1. Check the engine oil level **daily**, when in use. Make certain that proper oil level is maintained. **NEVER** overfill.
2. Change the break-in oil and filter after the first **8 hours** of operation. Thereafter, change oil and oil filter every **100 hours** of operation. **USE ONLY ENGINE MANUFACTURER'S BRAND OIL FILTERS. ANY OTHER TYPE OIL FILTER WILL VOID YOUR ENGINE WARRANTY.** Torque drain plug to 10 ft lbs.

Oil Recommendation. See "ENGINE OIL REQUIREMENTS" in Operations section.

NOTE: Using other than service class SG, SH, SJ or higher oil or extending oil change intervals longer than recommended can cause engine damage.

3. Check the spark plugs every **200 hours**. Clean if necessary. Replace the spark plugs every **1000 hours**. **NOTE:** Never sandblast spark plugs. Spark plugs should be cleaned by scraping or wire brushing.
4. Replace the air cleaner element every **year**.
5. Replace the in-line gas filter every **500 hrs**.

NOTE: For additional engine service information, obtain the engine manufacturer's manual from any authorized service center. If service or repair is required, contact an authorized engine manufacturer's service center. You will need to provide the serial number of the engine.

Engine oil capacity including filter is approximately 1.7 to 1.9 quarts.

Vacuum Pump

Refer to the Vacuum Pump Operation and Service Manual for specific instructions.

Lubrication: We recommend that you use AEON PD-XD synthetic lubricant. AEON PD-XD synthetic lubricant is formulated especially for AEON PD-XD rotary positive displacement blower service to provide maximum protection for all operation temperatures

NOTE: AEON PD-XD synthetic lubricant is the oil which PROCHEM puts in the vacuum pump at the factory. Topping off or adding petroleum oil to synthetic oil is NOT recommended.

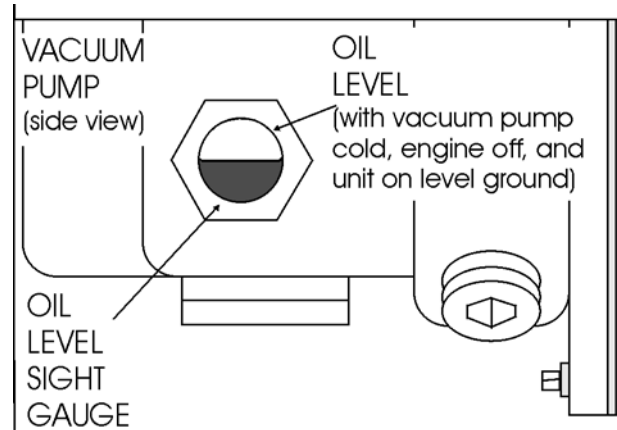

1. Check the oil level **daily** to assure the proper level. **PROPER LEVEL** cannot be overemphasized. Too little oil will ruin bearings and gears. Too much oil will cause overheating. Use the illustration as a guide when adding oil.
2. To prevent rust from building up inside the vacuum pump (if moisture exists) we have provided a lubrication cup on the front of the unit.

First run the unit at least **1 minute** to remove any moisture from the vacuum pump. Next, fill the lubrication cup with water displacing lubricant, for **5 seconds** while the unit is running and the vacuum inlets are sealed. Do this at the end of **each working day**.

3. Drain, flush and replace oil **every 1500 hours or yearly, whichever comes first**. Change oil more frequently if inspection so indicates.

Vacuum pump oil capacity is approximately 14 ounces at gear end.

4. Vacuum pump lubrication is vital to performance of our pump. Failure to follow the maintenance schedule in the "Maintenance Schedule" can lead to permanent damage to your blower.

Refer to the Vacuum Pump Operation and Service Manual for specific instructions.

5. Bearings on the drive end of the blower require grease lubrication every 250 hours of operation.

Solution Pump

1. Check the crankcase oil level **daily** to assure the proper level. Use the illustration as a guide when checking the oil level. If the level has dropped, check for the source of leakage and repair.
2. Remove yellow filler cap with attached dipstick. Oil level should be between marks on the dipstick or use the sight glass located on the non-shaft side of the pump.

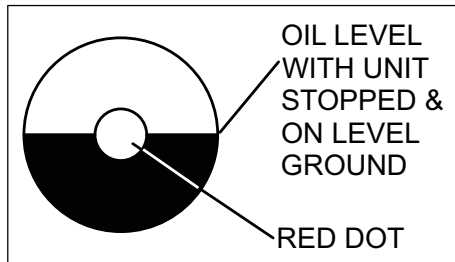

3. Change the crankcase oil with GP Pump Crankcase Oil, after the **first 50 hours** of operation. Drain and refill the crankcase oil with GP Pump Crankcase Oil **every 500** hours thereafter.

Solution pump oil capacity is approximately 14.0 ounces.

Vacuum Inlet Filter (in Waste Tank)

1. The vacuum filter in the waste tank should be removed and cleaned **daily**. If this is done, the filter will last for a long period of time.

Vacuum Relief Valve

The vacuum should be set at 13" Hg. Connect a 50 foot vacuum hose and a 50 foot solution line to the wand. Start the truckmount and bring the engine up to maximum operating speed. Once at maximum speed, place the wand head to the floor and wet the carpet. Seal the wand head to the wet floor and check the vacuum gauge reading. If adjustment is required, shut the unit down and adjust the vacuum relief valve locking nut tension. Start your unit and reread the vacuum gauge. Repeat process until gauge reads 13" Hg.

Vacuum Pump Drive Belts

To tighten the vacuum pump belts:

1. Loosen the four nuts which hold the vacuum pump mount in place.
2. Turn the adjusting bolts until the proper belt tension is achieved (1/2" deflection in the center of the belt, halfway between the pulleys).

NOTE: When adjusting belt tension, make certain that the engine shaft and vacuum pump shaft remain parallel, and the belt tension is equal throughout the belt width.

3. After adjusting, re-tighten the four nuts which hold the vacuum pump mount in position. Check belt alignment with straight-edge.
4. Check for pulley groove wear, clean belts and pulley grooves, check for worn belts, proper belt tension, and pulley alignment after the **first 25 hours** and then again at **100 hours**.

Solution Pump Drive Belts

To tighten the solution pump belt:

1. Loosen the bolts which hold the solution pump mount to base.
2. Adjust the position of the belt tension adjusting bolt until the proper belt tension is achieved. (1/2" deflection in the center of the belt, halfway between the pulleys).
3. While checking the alignment, tighten the nuts which hold the solution pump mount to base.
4. Check belt and pulley every 100 hrs.

Float Valve (Water Box)

1. Check the float valve weekly for proper operation. If overfilling is a problem, check the plunger for a proper seal. Replace tip on plunger if needed.

NOTE: If the float ball has any water inside it must be replaced.

! CAUTION:

When replacing float ball, **DO NOT over-tighten**, as the rod can puncture the ball. Make sure to tighten the nuts on the rod.

! ATTENTION:

Au moment de remplacer le flotteur, **NE PAS trop serrer**, car la tige pourrait perforer le flotteur. S'assurer de serrer les écrous sur la tige.

2. Disassemble the valve and check the piston and seat for damage, replace if needed. See the "Illustrated Parts Listing" for a parts break-down.

Waste Tank Float Valve

The float valve in the waste tank shuts the unit down once the waste tank becomes full. Debris can collect around the hinge of the float valve. Check the float valve for debris at least once a month.

Waste Tank Strainer Basket

The strainer basket located inside the waste tank should be removed and cleaned whenever it is full of debris. This should be done on at the end of each job.

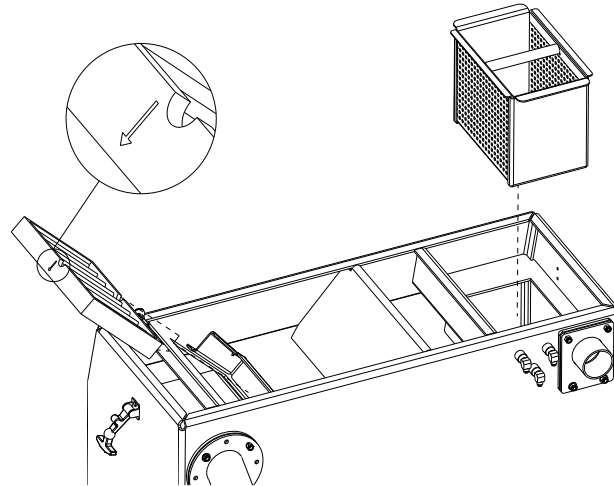

Waste Tank Vacuum Inlet Filter

The Vacuum Inlet Filter located inside the waste tank should be removed, cleaned and inspected at the beginning of each day. When replacing in tank ensure that flow indicating arrow is pointing down.

Solution Screen (Outlet)

Inspect the solution screen **after the first week** of running the unit by unscrewing the screen and remove any accumulated debris. Inspect the screen again at **2 and 4 weeks**.

The solution screen should then be inspected every month. However, if the screen has a frequent build-up of debris it should be inspected and cleaned more often.

Check Valve (Outlet)

Inspect the check valve when rebuilding the chemical pump or as needed. Remove and disassemble the check valve. Check the Teflon seat for debris or abnormal wear. Clean or replace seat if needed.

NOTE: Improper seating of the check valve poppet, damaged spring, or o-rings will cause poor operation of the chemical system.

For the procedure, see the "General Service Adjustments" section in this manual for details.

Chemical Pump

Rebuild the chemical pump **every 1000 hours**. This involves changing the diaphragm, plastic disk and check valves.

For the procedure, see the "General Service Adjustments" section in this manual for details.

NOTE: Inspect chemical inlet tube strainer daily.

Chemical and Temperature Control Valves

Examine the packing nuts on all of the valves **every 200 hours**. Keeping these valve packings properly adjusted will eliminate possible leakage from the valve stems and add to overall valve life.

For the procedure, see the "General Service Adjustments" section in this manual for details.

Pressure Regulator

Lubricate the o-rings and bullet **every 50 hours**. Use o-ring lubricant Part #86265430.

For the procedure, see the "General Service Adjustments" section in this manual for details.

Vacuum Hoses

To assure maximum hose life, we recommend that the hoses be washed out with clean water at the end of each **working day**.

High Pressure Solution Hoses

Inspect your high pressure solution hoses for wear after the **first 100 hours** of use. Inspect **every 25 hours thereafter**. If hoses show any signs of damage or impending rupture, **replace the hose**.

WARNING:

DO NOT attempt to repair high pressure hoses! Repairing high pressure solution hoses may result in severe burns and serious injury!

AVERTISSEMENT:

NE PAS tenter de réparer les flexibles à solution à haute pression! Tenter de réparer des flexibles à solution à haute pression pourrait causer des brûlures et des blessures graves!

All high pressure solution hoses must be rated for 3000 PSI at 250°F. Thermoplastic hoses do not meet these specifications and should not be used. Severe burns and injury may result if the hoses do not meet these requirements.

Optional Waste Pump-Out

At the end of each work day, make certain that you remove any debris or sediment which may be inside the waste pump by pumping fresh water through the pump.

General Service Adjustments

! WARNING:

USE EXTREME CAUTION the high-speed mechanical parts as well as high temperature components may result in severe injury, severed limbs, or fatality.

! AVERTISSEMENT:

FAIRE PREUVE DE LA PLUS GRANDE PRUDENCE les pièces mécaniques à haute vitesse de même que les composants à haute température pourrait causer des blessures graves, des amputations ou la mort.

Engine Speed

This unit uses a factory installed engine governor. The engine speed is adjusted by pulling the throttle out to maximum travel for high speed operation. For lower temperature or vacuum setting, rotate knob clockwise two turns or as needed to obtain desired temperature and vacuum settings. Pushed in, the engine is at idle speed (1400 rpm). With throttle pulled out, engine operates at maximum rpm (2950).

! CAUTION:

DO NOT attempt to adjust without a tachometer and NEVER adjust the engine to exceed stated maximum RPM (Full Load). Permanent damage may occur.

! ATTENTION:

NE PAS tenter d'effectuer un réglage sans tachymètre et ne JAMAIS régler le moteur de façon à excéder le nombre de tours par minutes indiqué (pleine charge). Cela pourrait cause des dommages permanents.

Check Valve (Solution Outlet)

Inspect the check valve whenever doing service on the chemical pump or if flow problems occur in the chemical system:

1. Remove the check valve. Be sure the small o-ring for the seat comes out with the check valve.

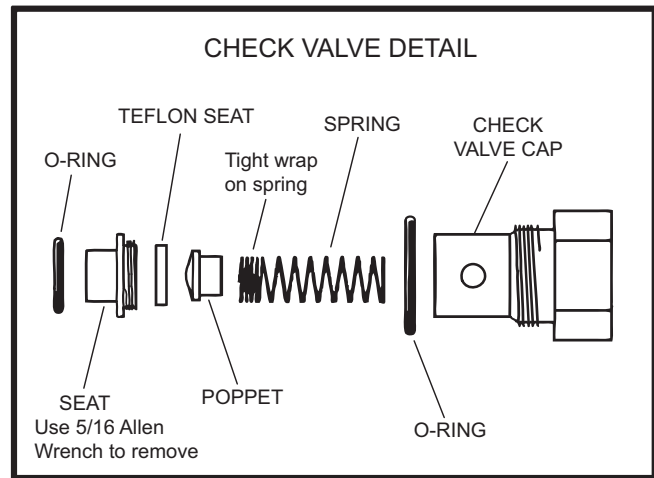

2. Remove the seat, using a 5/16" Allen wrench.
3. Check the Teflon seat for debris or wear. Clean or replace Teflon seat if needed.
4. Clean the poppet and spring, inspect for wear or damage, and replace as needed.
5. Re-assemble the check valve. Start the seat by hand, tighten using a 5/16" Allen wrench. **DO NOT** over-tighten seat.

NOTE: Improper seating of the check valve poppet, damaged spring or o-rings will cause poor operation of the chemical system.

6. Lubricate the o-rings with o-ring lubricant Part #86255430, PRV NO. 05-008035 and reinstall.

Water Box

1. Check inlet strainer for debris and blockage. A blocked strainer could damage the solution pump if water flow is restricted.
2. Inspect water box float valve for freedom of movement and water leaking past valve.

Chemical Pump

The only repairs which the chemical pump may require are the replacement of the diaphragm, plastic disk or check valves. To replace the diaphragm and plastic disk unscrew the cover from the body. When replacing the diaphragm, lubricate the outer edges of the diaphragm with o-ring lubricant Part #86265430 and reassemble. To replace the check valves, unscrew the check valve caps. Replace the check valves and reassemble, using new o-rings.

DO NOT attempt to re-use o-rings once the check valves have been removed. See the “Illustrated Parts Listing” for a parts break-down on the chemical pump.

Solution and Vacuum Pump Drive Belts

Use only exact replacement for system drive belts. Use only exact manufacturer and models for replacements.

⚠ CAUTION:

Make certain that when you re-torque these screws, that you use a clockwise pattern and continue until proper torque is achieved.

⚠ ATTENTION:

S'assurer, au moment de resserrer ces vis, d'utiliser un mouvement de rotation dans le sens des aiguilles d'une montre et de continuer jusqu'à ce que le couple souhaité soit atteint.

Torque Value		
Component	Inch/lbs	Foot/lbs
Rear Engine Hub	300	25
Vacuum Pump Hub	300	25
Front Engine Pulley	108	9

Packing Nut Adjustments for Chemical Valves

Examine the packing nut on all chemical valves for proper tension every **200 hours**. When turning the knob, there should be a small amount of resistance. If not, slightly tighten the packing nut. **DO NOT** over tighten. Keeping the valve packings properly adjusted will eliminate possible leakage from the valve stem and add to overall valve life.

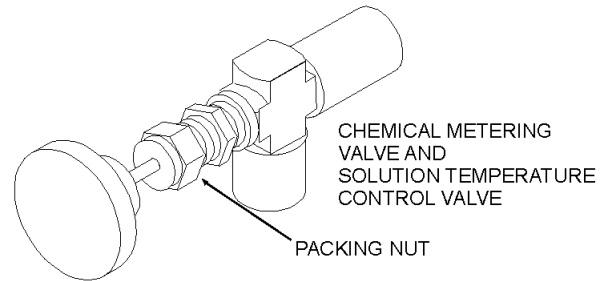

Pressure Regulator

The pressure regulator serves to maintain water pressure at a preset point and to bypass water back to the water box.

To adjust:

1. With your unit running, close the cleaning tool valve. Check the pressure gauge. Open the tool valve. We recommend setting the pressure regulator so that the pressure gauge reads 450 PSI with the tool valve open.

When the tool valve is opened, there is an approximate drop of 50 PSI in pressure. If there is a pressure drop greater than 100 PSI, it may be necessary to lubricate the o-ring in the pressure regulator.

2. If the pressure regulator requires adjustment, loosen the locking nut, then turn the adjusting body (cap) (while observing the pressure gauge on the control panel) until the desired pressure is obtained. Retighten the locking nut.

WARNING:

DO NOT loosen the adjusting body (cap) all the way (counterclockwise) or remove it while the unit is running.

AVERTISSEMENT:

NE PAS desserrer complètement le boîtier de réglage (capuchon) (dans le sens contraire des aiguilles d'une montre) ou le retirer alors que l'appareil est en marche

We recommend that you lubricate the pressure regulator o-ring every **50 hours**, or whenever required. If you do not, the stem may become seized due to inadequate lubrication. If this occurs:

- a. Shutdown the unit.
- b. Relieve all pressure from the water system.
- c. Remove the cap from the pressure regulator and remove the stem with long nose pliers.
- d. Clean and lubricate stem.
- e. Reassemble pressure regulator.

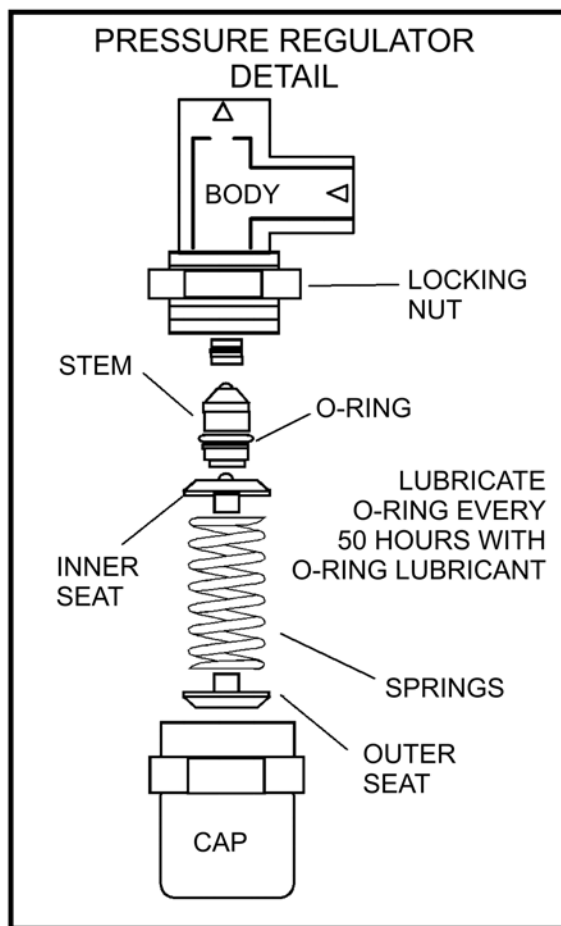

Troubleshooting

PROBLEM	CAUSE	SOLUTION
<p>Loss of solution pump pressure.</p> <p>With the cleaning tool open, the solution pressure gauge reads below the normal operating pressure.</p>	Water supply is turned off or the float valve is stuck or improperly adjusted.	Turn the water supply on or up. Check for kinks in the water supply hose. Examine the float valve and adjust or replace.
	Solution pump inlet supply line is plugged or drawing air.	Examine the water inlet strainer inside the water box. Remove accumulated debris and replace if required. Check for suction leaks and loose clamps or fittings. Tighten any loose fittings or clamps. Replace any ruptured hose(s).
	Improper engine speed	Using a tachometer, check the engine speed. Full throttle engine speed is 3200 RPM. Idle engine speed is 1400 RPM. Refer to the "engine speed" section for instructions on how to re-adjust.
	Pressure regulator o-ring is dry.	Lubricate o-ring, using o-ring lubricant Part #86265430.
	Pressure regulator has worn o-ring	Check o-ring. If necessary, replace.
	Pressure regulator is dirty, stuck open, or improperly adjusted.	Clean or repair regulator. Adjust to working pressure. Lubricate o-ring, using o-ring lubricant Part #86265430.
	Low pump volume. (Measure the amount of water being returned to the water box from the pressure regulator. It should fill a gallon container about every 17 seconds).	Examine the check valves, plunger cups, and cylinder head on the solution pump. Repair, whenever required (refer to the solution pump service manual).
	Defective solution pressure gauge.	Replace gauge
	Orifice (spray nozzle) in the cleaning tool is worn, defective, or wrong size.	Replace Nozzle or change nozzle size.
	Debris clogging water lines or water inlet disconnect.	Clean or replace as needed.
	Belt loose or broken	Re-tension or replace as needed.
	Loss of pump prime	Manually prime solution pump.
	Temperature Balance Orifice missing	Replace Orifice.
<p>Loss of solution volume at cleaning tool orifice.</p> <p>Solution gauge reads normal.</p>	Plugged orifice and/or screen in the cleaning tool.	Unplug or replace orifice and/or screen
	Internal block between the pressure regulator manifold and the solution manifold, or the solution screen is clogged	Inspect all lines, remove accumulated debris which is blocking proper flow. Replace any defective hoses. Remove, inspect, and clean the solution screen. De-scale unit and install a water softener, if necessary.
	Outlet check valve is plugged	Examine the check valve, remove any debris
	Defective quick-connect on one or more of the high pressure hoses.	Replace defective quick-connects(s) on high pressure hoses(s).
	Cleaning tool valve is malfunctioning.	Repair or replace valve.
	Hose inner lining is constricted.	Remove restriction or replace hose.
	Air leak in chemical supply line, priming valve or metering valve.	Check for air leaks. Replace faulty parts.

PROBLEM	CAUSE	SOLUTION
Loss of vacuum While cleaning, the vacuum is not up to specification. Engine RPM is normal.	Vacuum gauge is giving an improper reading.	Examine the tubing between the vacuum relief valve and the vacuum gauge and remove any blockage.
	Vacuum hose(s) is damaged, causing a suction leak.	Inspect hose(s), repair or replace.
	Waste tank gaskets not sealing properly, not positioned properly	Inspect the gaskets. Repair or replace gaskets as necessary. Re-position lid, inlet and outlet.
	Plugged vacuum hose or vacuum plumbing between vacuum inlet and strainer basket.	Unplug vacuum hose or inlet plumbing.
	Waste tank filter or strainer basket is plugged.	Clean or replace filter. Clean strainer basket.
	Loose vacuum pump drive belts.	Tighten the drive belts
	Waste tank drain valve is damaged or left open, causing a vacuum leak.	Close drain valve, if open. Remove the drain valve and, after inspecting, replace the defective components.
	Vacuum relief valve requires adjustment or has a vacuum leak due to damaged diaphragm.	Re-adjust the vacuum relief valve. If the vacuum does not increase, remove and inspect the relief valve diaphragm. If damaged, replace
	Vacuum exhaust heat exchangers are plugged with lint.	Remove and clean.
	Vacuum pump is worn out.	Replace the vacuum pump.
Excessive Vacuum	Improper throttle adjustment.	Adjust throttle to set desired vacuum pressure.
	Vacuum obstruction	Inspect hoses for obstructions.
	Vacuum relief valve requires adjustment.	Readjust the vacuum relief valve.
Loss of chemical With the cleaning tool valve open, no chemical	Chemical pump is improperly primed.	Refer to chemical pump priming instructions.
	The strainer at the inlet end of the chemical inlet tube is clogged	Unclog the strainer. If damaged, replace.
	Suction leak in the inlet tube leading into the chemical pump.	Inspect inlet tube and flow meter for air leaks or damage and replace, if required.
	Chemical pump check valve(s) is clogged	Remove any debris from the chemical check valve(s). Replace chemical check valve(s) or seals, if necessary.
	Chemical prime/on-off valve or chemical metering valve is defective.	Replace valve(s).
	Chemical pump diaphragm is ruptured.	Disassemble the chemical pump and replace the damaged diaphragm and plastic disk.
	Defective cylinder in the solution pump.	Measure the pump volume. If the pump volume is less than normal, refer to "Loss of Pump Volume" in the Troubleshooting section in this manual.

PROBLEM	CAUSE	SOLUTION
Chemical flow meter indicates flow with the tool valve closed	External leak in chemical piping	Tighten fittings. Re-apply thread sealant where required. If any fittings are damaged, replace.
	Outlet check valve is full of debris or damaged, not allowing it to close properly	Close the chemical valve on the instrument panel. If the flow meter does not indicate flow, remove debris or replace check valve, if necessary.
	Chemical pump diaphragm is ruptured	Close the chemical valve on the instrument panel. If the flow meter still indicates flow, replace the chemical pump diaphragm and plastic disk.
	Internal leak in chemical valve causing continual flow through prime tube returning to container.	Tighten valve packing nut (see "General Service Adjustments" section in this manual). Replace valve, if necessary.
Solution pump does not engage	Solution pump circuit breaker has been tripped	Check the solution pump circuit breaker on the control panel. Press the circuit breaker reset button.
	Defective electrical connection in the console wiring or defective switch.	Examine switch, electrical connections, and wiring. Repair any defective connections. If there is power going to the switch but not going out, replace the defective switch.
	Solution pump has not been activated	Turn solution pump switch to on.
	Defective solution pump clutch. <i>NOTE: The clutch may be manually engaged by inserting two 1/4-20 x 1/2 bolts. Line up the holes on the clutch and insert the bolts. To disengage the pump, remove the bolts.</i>	If there is power in the switch, but not power at the clutch, replace the defective wire. If there is power at the clutch, replace the defective switch.
	Loose or broken solution pump belt.	Tighten or replace belt.
Engine will not start	Main circuit breaker on the control panel has been tripped.	After inspecting the unit to determine the cause of the tripped circuit breaker, press the reset button.
	Loose or corroded battery.	Clean, tighten, or replace the battery terminals.
	Dead battery.	Recharge or replace battery.
The engine does not turn over	Defective ignition switch.	Test ignition switch for power going into the switch. If there is power going in but NO power going out, replace the switch.
	Defective starter motor.	Test the starter motor. If necessary replace.
	Vacuum pump seized.	Refer to vacuum pump manufacturer's service & repair manual.
Starter turns over engine, but will not start	Waste tank is full.	Empty the waste tank.
	Defective fuel pump.	Replace the fuel pump.
	Loose or broken wires leading to waste tank float switch.	Repair or replace any broken electrical connections.
	Defective float switch in the waste tank.	Check switch for proper operation, replace as necessary.
	Internal engine problem.	Consult the engine manufacturer's service and repair manual or contact engine manufacturer's authorized repair center.

PROBLEM	CAUSE	SOLUTION
Starter turns over engine, but will not start	Engine is malfunctioning	Refer to Kohler Engine Operation and Maintenance Manual.
Engine stops running- While doing normal cleaning, the engine stops running	Engine is out of gasoline	Add gasoline to the fuel tank.
	Waste tank is full	Empty waste tank.
	Main circuit breaker on the control panel has been tripped.	After inspecting the unit to determine the cause of the tripped circuit breaker, press the reset button.
	Engine coolant temperature has exceeded 240°F, triggering the high temperature switch to shut the unit down.	Determine the cause of the overheating before restarting the unit. Refer to the Kohler Engine Operation and Maintenance Manual.
	Defective fuel pump.	Replace fuel pump.
	Defective float switch inside the waste tank.	Check switch for proper operation. Replace as necessary.
	Oil pressure gauge on engine has shut down, due to insufficient oil pressure.	Refer to the Kohler Engine Operation and Maintenance Manual. DO NOT restart the engine until the cause is determined and corrected.
	No ignition in the engine or engine is malfunctioning.	Refer to the Kohler Engine Operation and Maintenance Manual.
Excessive heating	Flow restriction caused by hard water scaling.	Descale unit, repair or replace damaged plumbing components as necessary. Install water softener.
	Not enough water flow.	Check jet size of tool.
Heat exchanger leaks <i>NOTE: The heat exchanger will produce water condensation discharge at times during normal operation. DO NOT confuse this with a leak.</i>	Engine/vacuum exhaust heat exchangers are damaged from frozen water.	Inspect heat exchangers for leaks. Visually inspect for damage. Pressure check after removing from the unit. (Maximum test pressure 1200 PSI).
Loss of temperature The heat output of the unit is LESS than normal.	Temperature relief valve on water box is stuck open.	Clean temperature relief valve and test. Replace, if necessary.
	Engine RPM is low.	Reset engine RPM.
	Defective temperature gauge.	Test gauge and sensor. Replace failed component.
	Temperature balance orifice missing	Replace orifice
Automatic waste pump is malfunctioning or not operating normally <i>NOTE: When replacing either the pump or float switch on internal (in tank) pumpout, use new electrical connectors and heat shrink. Inspect connection for watertight seal.</i>	Defective waste pump float switch.	Replace float switch.
	Broken diaphragm.	Replace diaphragm.
	Weak battery.	Charge or replace battery if needed. Check charging station.
	Pump-out circuit breaker on control panel has been tripped.	After inspecting waste pump to determine the cause of the tripped circuit breaker, press the reset button.

PROCHEM[®]

Kärcher Group

Spare Parts List

1.001-119.0, 1.001-138.0, 1.001-141.0, 1.001-162.0

Legend GT

From Serial Number (Ref No1*)

*See Serial Number Page
or call manufacturer

How to Use this Spare Parts List

The PARTS LIST section contains assembled parts illustrations and corresponding parts list. The parts lists include a number of columns of information:

- REF - column refers to the reference number on the parts illustration.
- PART NO. - column lists the part number for the part.
- QTY - column lists the quantity of the part used in that area of the machine.
- DESCRIPTION - column is a brief description of the part.
- SERIAL NO. FROM - If this column has an (*) and a Reference number, see the SERIAL NUMBERS page in the back of your manual. If column has two asterisk (**), call manufacturer for serial number. The serial number indicates the first machine the part number is applicable to. The main illustration shows the most current design of the machine. When a boxed illustration is shown, it displays the older design.
- NOTES - column for information not noted by the other columns.

NOTE: *If a service or option kit is installed on your machine, be sure to keep the KIT INSTRUCTIONS which came with the kit. It contains replacement parts numbers needed for ordering future parts.*

How to Use this Spare Parts List 1

Table of Contents 2

Frame 3

Side Panel 5

Control Panel - Upper 1 7

Control Panel - Upper 2 9

Engine 11

Vacuum Pump 13

Solution Pump 1 15

Solution Pump 2 17

Heat Exchanger 19

Pressure Regulator & Temperature Control Valve 21

Solution Outlet 23

Water Box 25

60 Gallon Waste Tank 27

100 Gallon Waste Tank 29

Fuel Pump 31

Battery Floor Mount 33

Chemical Jug Floor Mount 35

Wiring Diagram 37

Hose Diagram 38

Options

Hose Accessories 41

Exhaust - Optional 43

Automatic Pumpout - Dual Diaphragm - Optional. 45

Wand - Titanium Six Jet - Optional 47

Wand - Ergo Titanium Six Jet - Optional. 49

Wand - Quad Jet - Optional 51

Wand - Tri Jet -Optional 53

Stair Tool - Optional 55

Upholstery Tool - Optional 57

Shelf Assembly - Optional. 59

Water Tank Dual with Demand Pump - Optional . 61

Water Tank - Demand Pump - Optional 63

Auxiliary Water Tank with Pump-Optional 65

Auxiliary Water Tank - Optional 67

Hose Reel - Optional. 69

Motorized Hose Reel - Tank - Optional. 71

Motorized Hose Reel - Optional 73

E Z - Charge Water Softener - Tank & Tray - Op-
tional 75

E Z - Charge Water Softener - Filter - Optional . . 77

E Z - Charge Water Softener - Brine System - Op-
tional 79

Serial Number 81

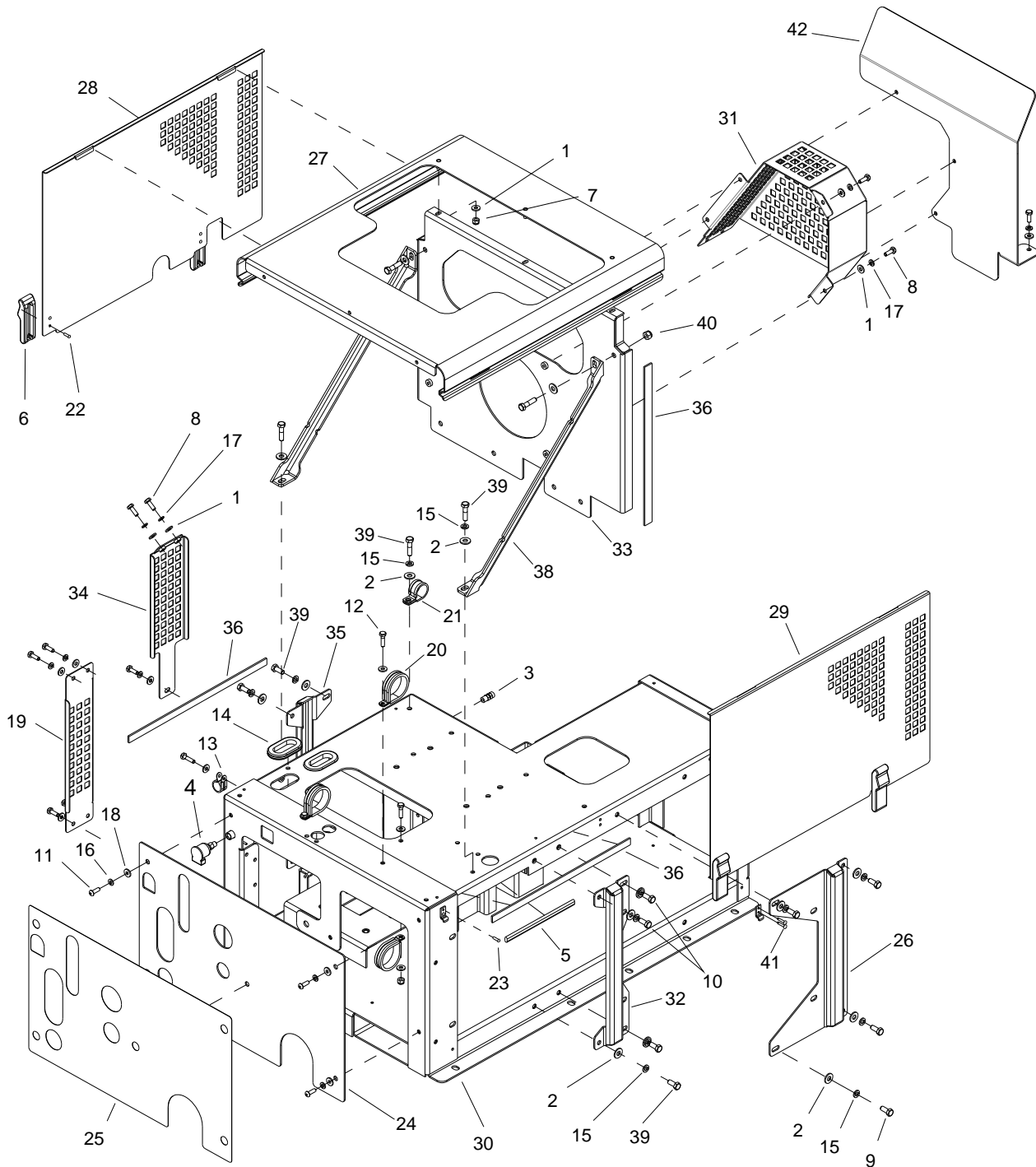

REF	PART NO.	QTY	DESCRIPTION	SERIAL NO. FROM	NOTES
1	86270330	26	FLATWASHER, 1/4		
2	86278830	17	WASHER, 5/16 FLAT PLTD		
3	86177640	1	CONN, 1/8P X 1/4POLY BR		
4	86178700	1	CUP, OIL FILL 1/8P		
5	86194670	1	TRIM, FLEX, TM		
6	86161800	4	LATCH, CONCEALED KEEPER		
7	86005680	7	NUT, 1/4-20 HEX NYLOCK		
8	86274750	15	SCR, 1/4-20 X 3/4 HHCS		
9	86006760	4	SCR, 5/16-18 X 3/4 HHCS GR5		
10	86274910	2	SCR, 5/16-18 X 1.25 HHCS GR5		
11	86275460	5	SCR, 1/4-20 X 3/4 BHCS		
12	86275570	4	SCR, 1/4-20 X 1.00 HHCS GR5		
13	86233410	1	CLAMP, 3/4 DIA CUSHION .406 DIA		
14	86238500	2	GROMMET, 1.703IDX2.5ODX.125GRV		
15	86279130	15	WASHER, 5/16 SPLIT LOCK		
16	86279400	5	WASHER, 1/4 SPLIT LOCK BLK		
17	86010780	15	WASHER, 1/4 SPLIT LOCK		
18	86279520	5	WASHER, 1/4 ID FLAT BLK		
19	86313920	1	GUARD, BELT, FRONT		
20	86314700	3	CLAMP, CABLE, 1-3/4 "P" CUSHION		
21	86177430	1	CLMP, 1-1/16 ID X 3/8 BLT		
22	86191800	4	RIVET, 5/32 OD X .188-.250 GL AL		
23	86191810	8	RIVET, 5/32 OD X .251-.375 GL AL		
24	86309130	1	PNL, LOWER FRONT		
25	86409230	1	LABEL, LOWER FRONT PNL		
26	86310020	1	BRKT, HE SUPT		
27	86412340	1	HOOD, TOP		
28	86412350	1	HOOD, LEFT		
29	86412360	1	HOOD, RIGHT		
30	86393780	1	ASSEMBLY, SM SHT MTL FRAME		
31	86310470	1	GUARD, BELT		
32	86310810	1	BRKT, FRAME STIFFENER		
33	86369940	1	PNL, REAR ENGINE SUPT		
34	86313750	1	GUARD, BELT, LOWER REAR		
35	86313910	1	BRKT, LEFT FRAME STIFFENER		
36	86315490	4	GASKET, VIBE DAMPNR		
37	86373930	4	RIVET, 5/32 X.376-.500GL POP AL		
38	86369930	2	BRACKET, REAR STABILITY		
39	86006750	11	SCREW 5/16-18 X 1"HHCSGR5PLT NP		
40	86005750	6	NUT, 5/16-18 HEX NYLOCK STL GR2 ZNPLT		
41	86394280	1	SHIELD, LGT EXHAUST TUBE HEAT		

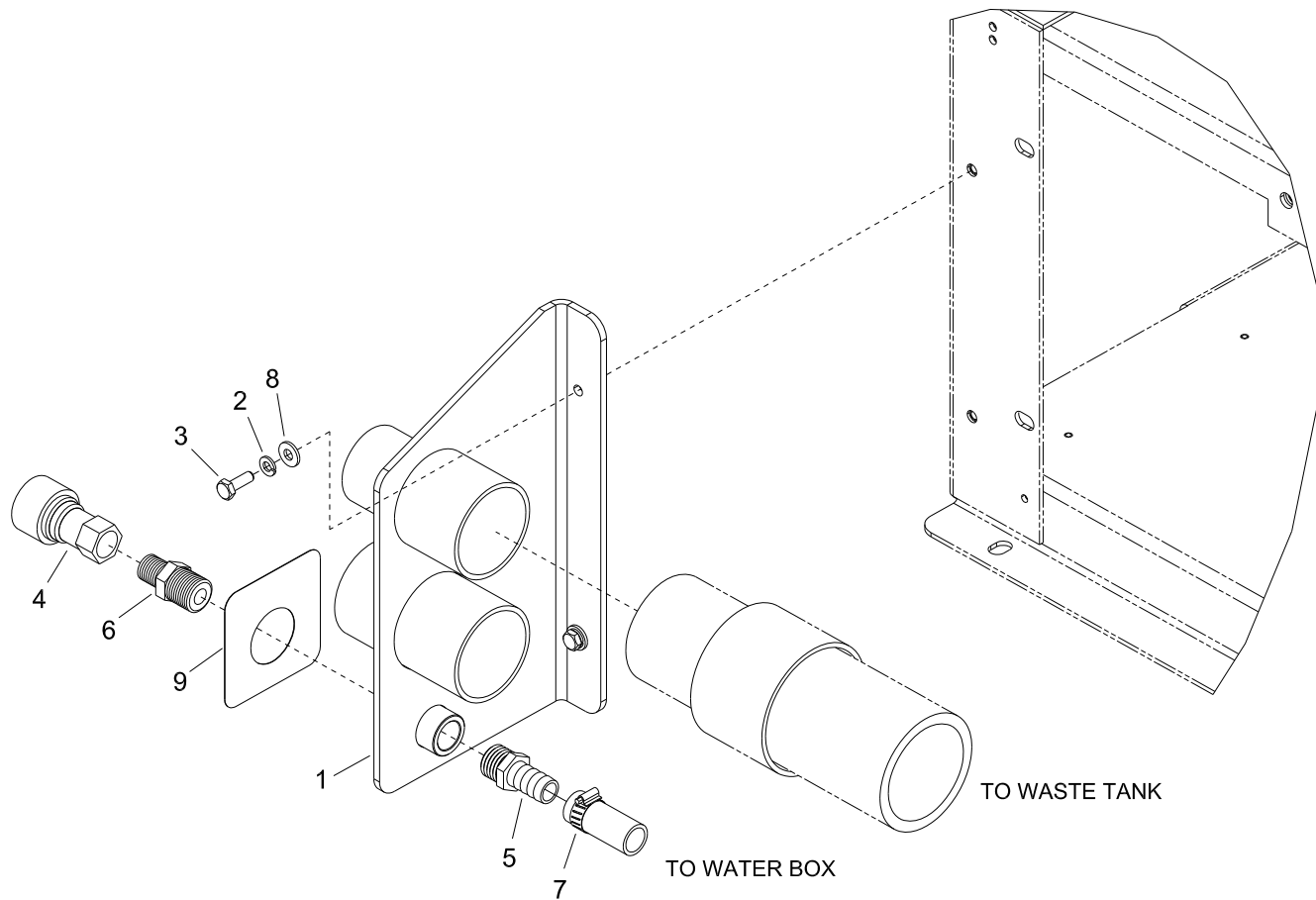

REF	PART NO.	QTY	DESCRIPTION	SERIAL NO. FROM	NOTES:
1	86327760	1	BRKT, WTR & VAC INLET, LGT BGT		
2	86010780	2	WASHER, 1/4 SPLIT LOCK		
3	86274750	2	SCR, 1/4-20 X 3/4 HHCS		
4	86179710	1	DSC, 3/8F X 3/8FP		
5	86181360	1	FTTG, BRB 1/2P X 5/8H BR		
6	86188210	1	NIP, 1/2 X 3/8 HEX BR		
7	86177260	1	CLMP,HOS#10 9/16MIN 1-1/		
8	86270330	2	FLATWASHER, 1/4		
9	86409240	1	LABEL, WTR & VAC INLET BRKT		

Control Panel - Upper 1

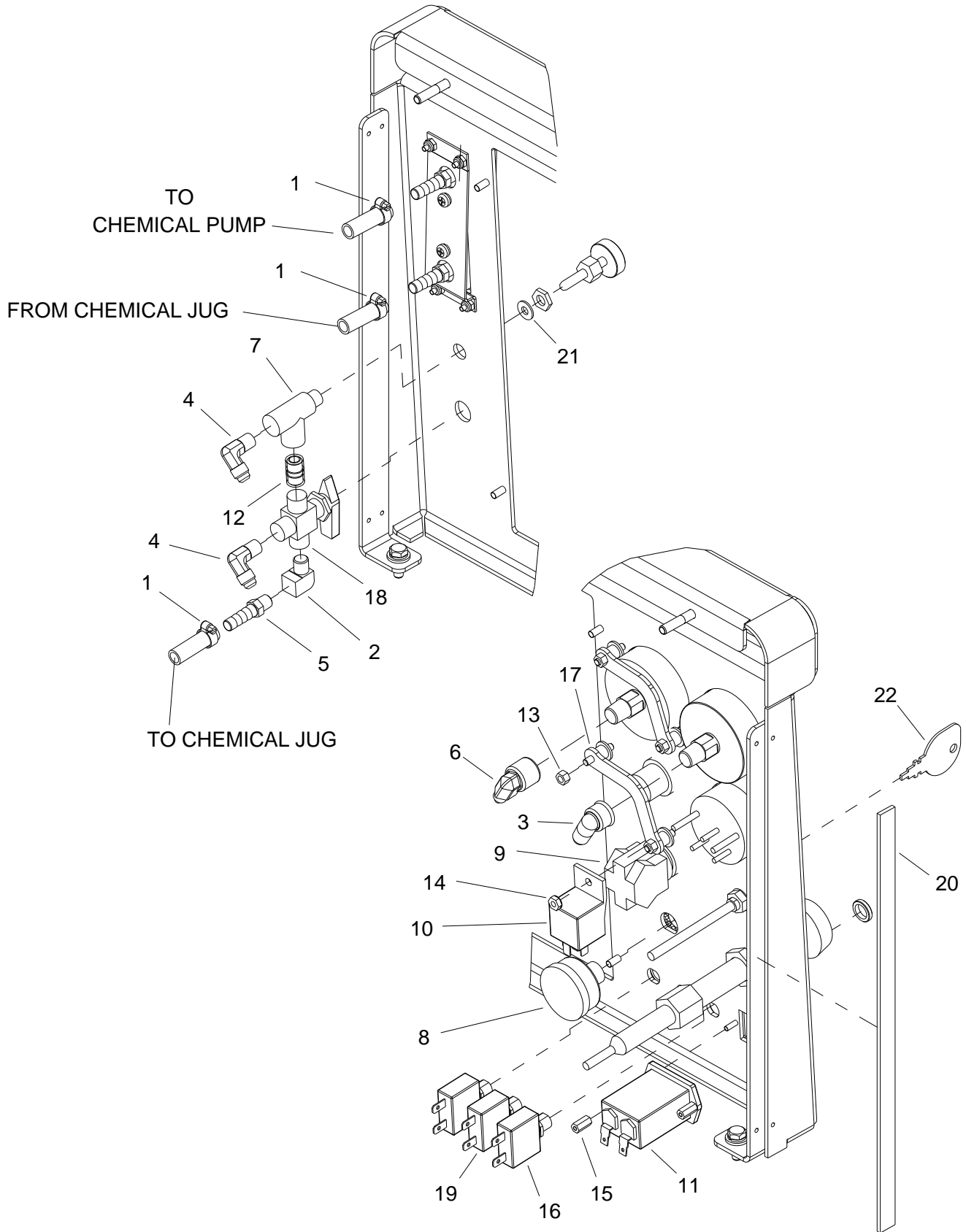

REF	PART NO.	QTY	DESCRIPTION	SERIAL NO. FROM	NOTES
1	86176990	3	CLAMP, HOSE #4 SST		
2	86180140	1	ELL, STREET 1/8 BR		
3	86180350	1	ELL, 1/4FP X 1/4T BR		
4	86180360	2	ELL, 1/8P X 1/4T BR		
5	86181300	1	FTTG, BRB 1/8P X 5/16H		
6	86180380	1	ELL, 1/4FP X 1/4POLY BR		
7	86195050	1	VALVE, METER 1/8FP		
8	86186020	1	KEYSWITCH		
9	86193760	1	SW, RTRY W/BYPASS NON-ILL		
10	86191740	1	RELAY, ENG SHTDWN		
11	86246890	1	METER, 0-60VDC HOUR		
12	86247720	1	NIPPLE, 1/8 CLOSE		
13	86136310	4	NUT, M5 X 4.7 HEX NYLOCK		
14	86005720	1	NUT, 8-32 HEX W/STAR		
15	86255920	2	STANDOFF, 6-32 X 1/2 HEX NYL		
16	86185610	1	BRKR, CIRCUIT, 30A		
17	86175680	2	BRKT, WIKA MOUNTING		
18	86297070	1	VALVE, 3-WAY BALL 1/8P		
19	86298280	2	BRKR, CIRCUIT, 20A		
20	86315490	2	GASKET, VIBE DAMPNR		
21	86329190	1	WASH, .446ID X .563OD X .010THK SST		
22	86185990	1	KEY, SWITCH TM (32-900174)		(KEY ONLY)

Control Panel - Upper 2

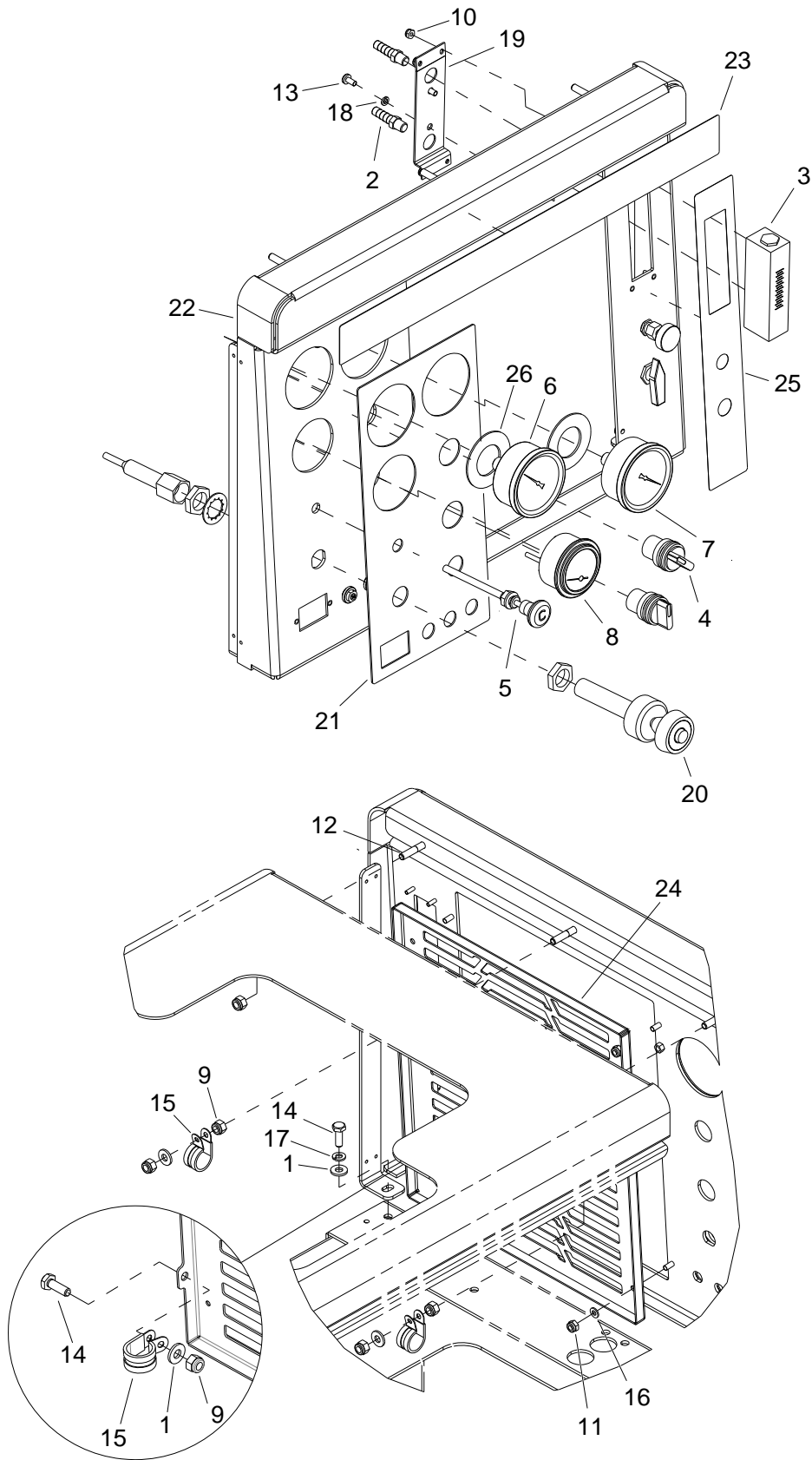

REF	PART NO.	QTY	DESCRIPTION	SERIAL NO. FROM	NOTES
1	86270330	5	FLATWASHER, 1/4		
2	86181300	2	FTTG, BRB 1/8P X 5/16H		
3	86181170	1	FLOWMETER 1/8FP		
4	86193750	1	SW, RTRY NON-ILLUM TM		
5	86176120	1	CABLE, CHOKE		
6	86181930	1	GAUGE, 0-1200 PSI		BRKT 86175680 INCLUDED
7	86181950	1	GAUGE, VACUUM, 15" HG		BRKT 86175680 INCLUDED
8	86181960	1	GAUGE, TEMP, DATCON		
9	86005680	6	NUT, 1/4-20 HEX NYLOCK		
10	86270920	4	NUT, 6-32 HEX NYLOCK SS		
11	86270990	4	NUT, 10-32 HEX NYLOCK SS		
12	86273820	3	SCR, 1/4-20 X 1.25 HHCS SS		
13	86274290	2	SCR, 10-32 X 3/8 PPHMS SS		
14	86274750	2	SCR, 1/4-20 X 3/4 HHCS		
15	86233410	3	CLAMP, 3/4 DIA CUSHION .406 DIA		
16	86279190	4	WASHER, #10 X .40 FLAT		
17	86010780	2	WASHER, 1/4 SPLIT LOCK		
18	86279470	2	WASHER, #10 SPLIT LOCK		
19	86017360	1	BRKT, FLOW METER		
20	86177540	1	CNTRL, THRTL, CLR/CLNR		
21	86409250	1	LABEL, CONTROL PANEL, PC		
22	86412370	1	PANEL, FRONT, LGT, PC		STANDARD FOR 10011190
-	86309910	1	PANEL, CONTROL, LGT, PC		STANDARD FOR 10011620
-	86335040	1	ASSY, CONTROL PNL, LGT VT		STANDARD FOR 10011380 AND 10011410
23	86409260	1	LABEL, FRNT HD, LGT, PC		
24	86312880	1	PNL, GRILLE, GT		
25	86409270	1	LABEL, CHEM PNL, GT		
26	86358480	2	SPACER, BEAUTY RING		
27	86399570	1	HARNES, LEGEND GT WIRING		NOT SHOWN

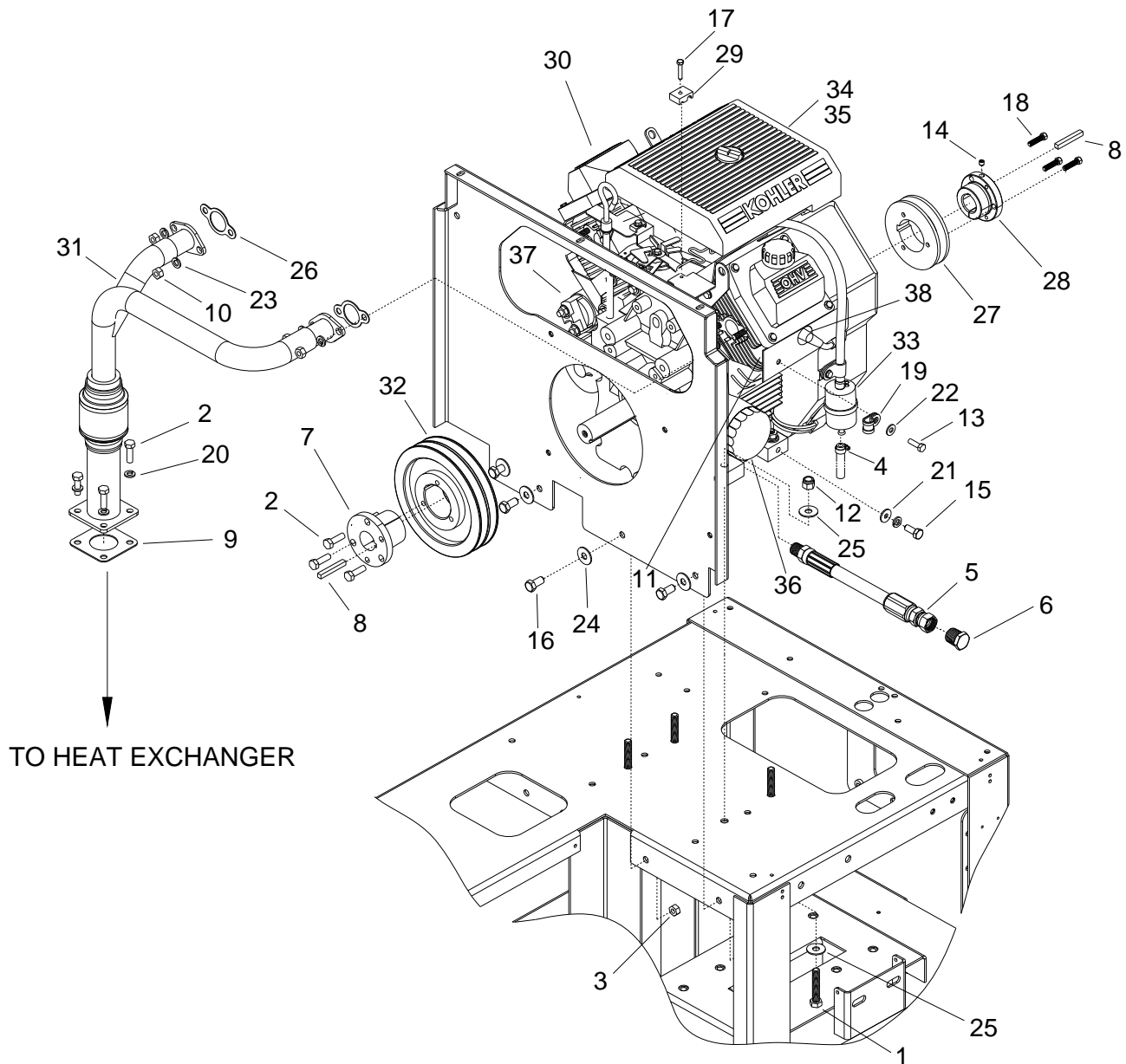

REF	PART NO.	QTY	DESCRIPTION	SERIAL NO. FROM	NOTES
1	86277830	4	SCR, 3/8-16 x 2" HXHD		
2	86273440	7	SCR, MACH 5/16-18 X 1" GR8		
3	86270830	4	NUT, 5/16-18 HEX NYLOCK SS		
4	86176990	1	CLAMP, HOSE #4 SST		
5	86183600	1	HOS, 3/8 X 10 (3/8P X 1/2T)		
6	86190550	1	PLUG, 1/2T		
7	86185350	1	HUB, P1 X 1-1/8		
8	86049230	2	KEY, 1/4 SQ X 1.88		
9	86182290	1	GSKT, EXH, KUB, D902/WG972		
10	86136280	4	NUT, M8 HEX		
11	86270990	1	NUT, 10-32 HEX NYLOCK SS		
12	86005770	4	NUT, 3/8-16 HEX NYLOCK		
13	86273980	1	SCR, 10-32 X 3/4 PPHMS SS		
14	86277930	1	SCR, 1/4-20 X 3/8 SSSCU DL		
15	86136640	1	SCR, M8 X 20 HHMS		
16	86006750	4	SCR, 5/16-18 X 1"HHCSGR5PLT NP		
17	86277890	1	SCR, M5 - 8 X 25MM STL, ZNC		
18	86277680	3	SCR, 1/4-20 X 1-1/4 HXHD GR8		
19	86233410	2	CLAMP, 3/4 DIA CUSHION .406 DIA		
20	86279130	4	WASHER, 5/16 X .583 X .078 SPL STL ZNPLT		
21	86010740	1	WASHER, 1/4 X 3/4 FLAT		
22	86270330	1	FLATWASHER, 1/4		
23	86279130	5	WASHER, 5/16 X .583 X .078 SPLSTLZNPLT		
24	86278830	4	WASHER, 5/16 X .875 X .083 FLT STL ZNPLT		
25	86279510	8	WASHER, 3/8 X 1 FLAT NP		
26	86182730	2	GSKT, EXHST, KHLR 25HP		
27	86191280	1	PULLEY, 1B36SH		
28	86185400	1	HUB, SH1		
29	86177130	1	CLAMP, CABLE, THROT/CHOKE		
30	86310480	1	ENGINE, KOHLER 23HP		
31	86311440	1	TUBE, EXHAUST, KOHLER 23HP		
32	86313550	1	PULLEY, 2TA62		
33	86315860	1	FILTER, FUEL KOH 23HP		
34	86315870	1	ELEMENT, AIR FILTER KOH 23HP		
35	86315840	1	PRE-CLEANER, KOHLER 23 HP		
36	86186320	1	KOH FLTR, OIL #1205001-S		
37	86315850	1	STARTER, SOLENOID SHIFT KOH 23HP		
38	86186360	2	KOH SPK PLG #1213202-S		

Vacuum Pump

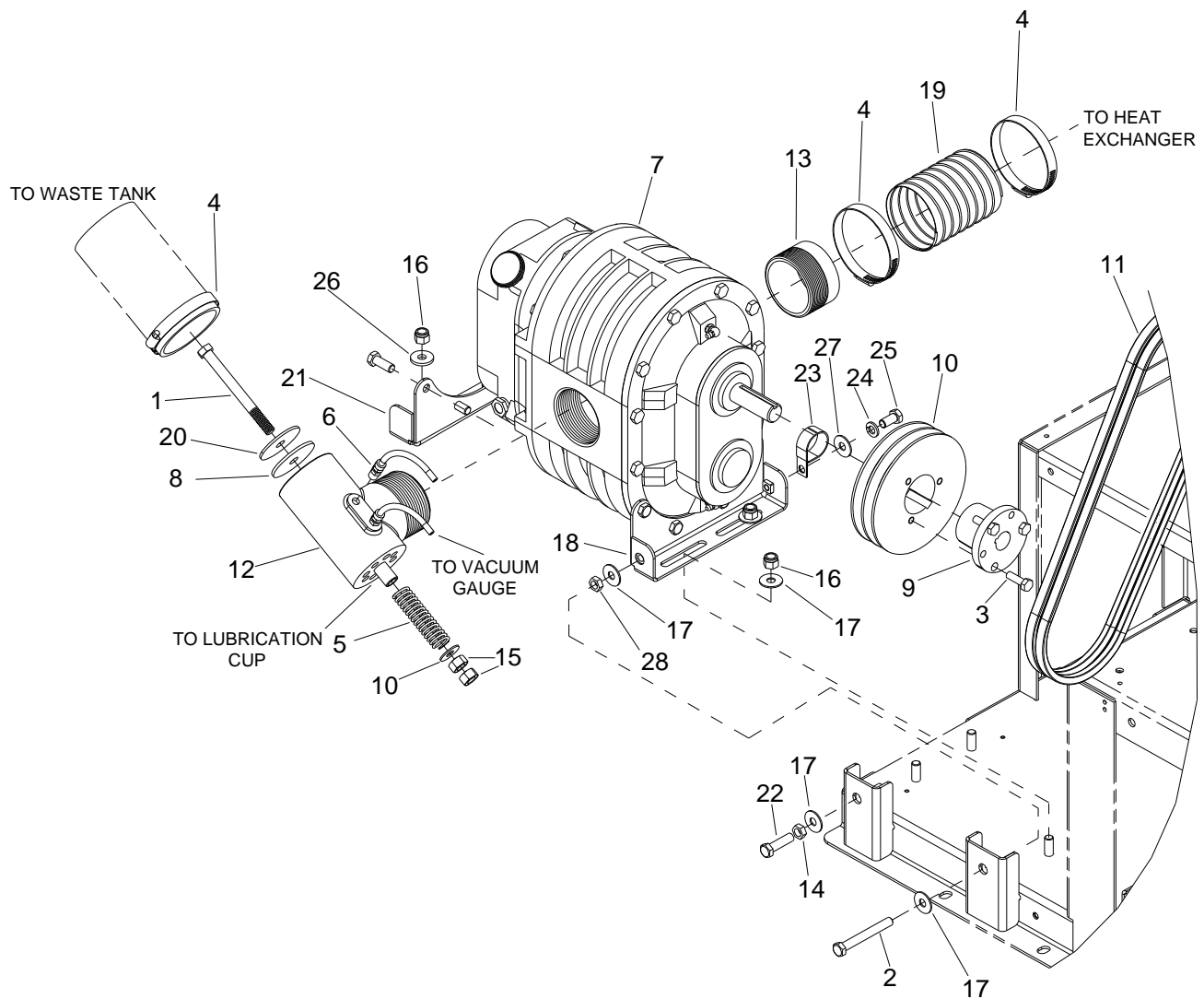

REF	PART NO.	QTY	DESCRIPTION	SERIAL NO. FROM	NOTES
1	86273320	1	SCR, CAP 7/16-14 x 4 HXHD		
2	86273420	1	SCR, CAP 3/8-16x3 ALL THD		
3	86273440	3	SCR, MACH 5/16-18 X 1" GR8		
4	86177010	3	CLAMP, HOSE #48		
5	86193230	1	SPRING, VAC REL VLV		
6	86177640	2	CONN, 1/8P X 1/4POLY BR		
7	86190700	1	PMP, VAC 4M-L		
8	86179580	1	DIAPHRAM, VAC REL VLV		
9	86185320	1	HUB, P1 X 7/8		
10	86191030	1	PULLEY, 2TA54		
11	86371980	2	BELT, BANDO AX41 PWR KING COG		
12	86180600	1	ELL, VAC REL VLV		
13	86188500	1	NIP, VAC EXH OUTL		
14	86005690	2	NUT, 3/8-16 HEX JAM		
15	86271070	2	NUT, 7/16-14 HEX		
16	86005770	4	NUT, 3/8-16 HEX NYLOCK		
17	86279510	5	WASHER, 3/8 X 1 FLAT NP		
18	86309350	1	BRKT, BLOWER MTG		
19	86311490	1	TUBING, FLEX, BLWR TO MFLR		
20	86311600	1	WASHER, VAC REL VLV, #4VAC		
21	86315540	1	BRKT, REAR BLOWER MTG		
22	86277830	1	SCR, 3/8-16 X 2" HXHD		
23	86177430	1	CLMP, 1-1/16 ID X 3/8 BLT		
24	86279130	1	WASHER, 5/16 SPLT STL ZNPLT		
25	86006760	1	SCREW, 5/16-18 X .75 HHCS		
26	86310690	2	WASHER, 3/8 X 1 X .125 FLT SS		
27	86278830	1	WASHER, 5/16 FLT STL ZNPLT		
-	86189090	1	OIL, AEON PD-XD (28G47 SUTORBILT)		NOT SHOWN
-	86368270	1	VENT PLUG, 3/8" NPT, 5L359		NOT SHOWN

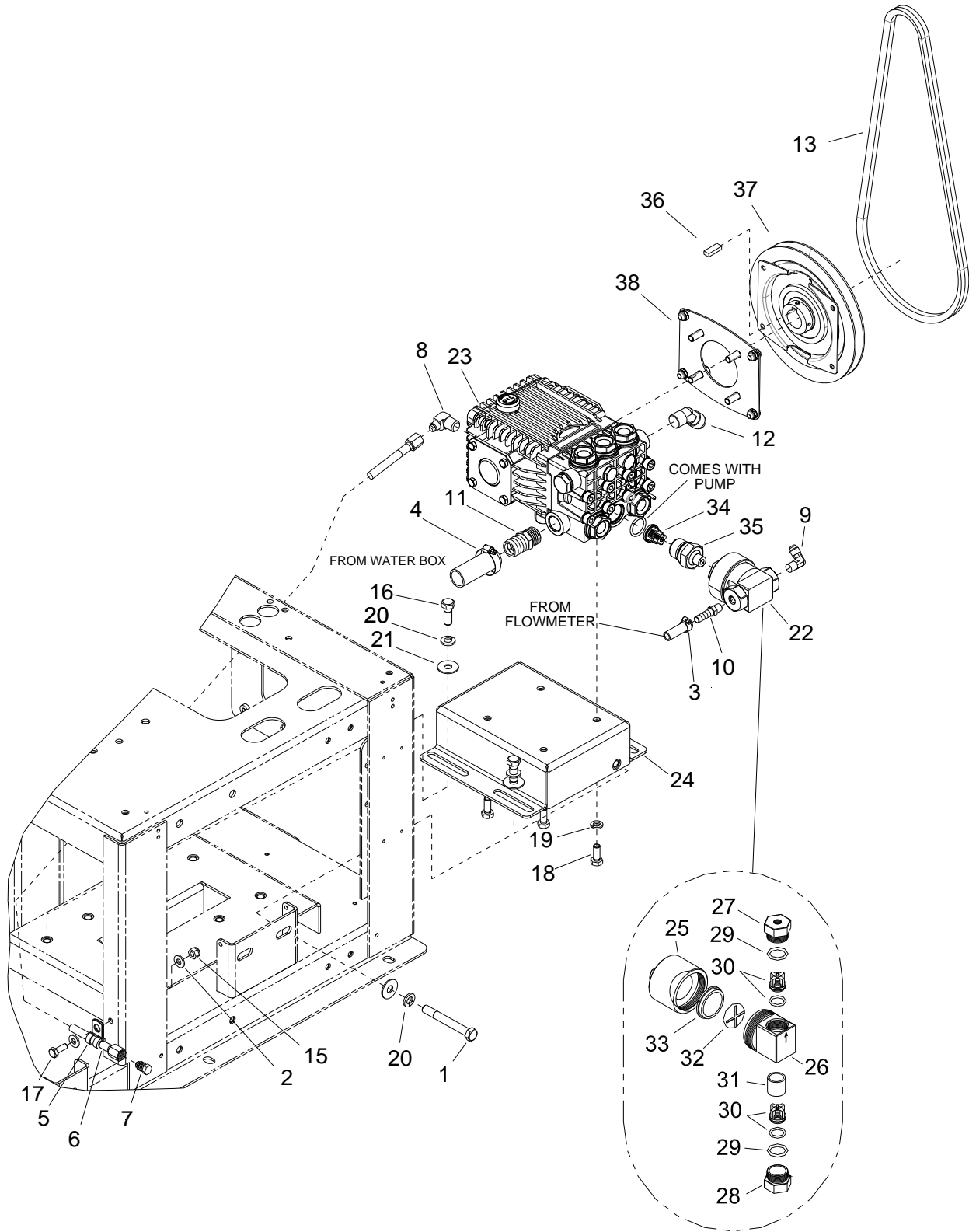

REF	PART NO.	QTY	DESCRIPTION	SERIAL NO. FROM	NOTES
1	86273420	1	SCR, CAP 3/8-16x3 ALL THD		
2	86270330	2	FLATWASHER, 1/4		
3	86176990	1	CLAMP, HOSE #4 SST		
4	86177310	1	CLMP, HOSE #16 1-1/2 MIN 1-3/4		
5	86177320	1	CLMP, 1/4 ID X 3/8 BLT		
6	86183700	1	HOS, 3/16X19(1/4FT BS) MET		
7	86190540	1	PLUG, 1/4T BR		
8	86180340	1	ELL, 1/4P X 1/4T BR		
9	86180360	1	ELL, 1/8P X 1/4T BR		
10	86181300	1	FTTG, BRB 1/8P X 5/16H		
11	86181370	1	FTTG, BRB 1/2P x 3/4H BR		
12	86180450	1	ELL, 3/8P X 1/2T 45 DEG. BR		
13	86175120	1	BELT, AX41 GOODYEAR MATCH		
14	86282770	1	LOOM, 1/4 HI TMP X 10"		
15	86005680	1	NUT, 1/4-20 HEX NYLOCK		
16	86006740	4	SCR, 3/8-16 X 1.00 HHCS GR5		
17	86274750	1	SCR, 1/4-20 X 3/4 HHCS		
18	86274860	4	SCR, M8 X 20 HHMS		
19	86279130	4	WASHER, 5/16 X .583 X .078 SPLSTLZNPLT		
20	86010790	5	WASHER, 3/8 SPLIT LOCK		
21	86279510	5	WASHER, 3/8 X 1 FLAT NP		
22	86191440	1	PUMP, CHEM, PULSE, GP		INCLUDES 25-33
23	86310490	1	PUMP, ASSY, GEN 3.5GPM		
24	86311170	1	BRKT, PUMP MTG		
25	86194630	1	PULSE PUMP, TOP COVER INLET		
26	86191340	1	PULSE PUMP, BODY		
27	86195120	1	VALVE CAP, 303 SST, OUTPUT		
28	86195100	1	VALVE CAP, 303 SST, INPUT		
29	86189290	2	O-RING, DURO,.862ID X .103CS		
30	86195110	2	VALVE KIT, ASM, CHEM, PULSE PUMP		
31	86192920	1	SPACER RING, 303 SST		
32	86249220	1	PLASTIC DISC		
33	86179550	1	DIAPHRAGM, CHEM PUMP		
34	86335860	1	CHECK VALVE, SOLN PUMP, LGT		
35	86335870	1	ADPTR, PULSE PUMP GP, LGT		
36	86350880	1	KEY, INTERPUMP CLUTCH		
37	86350930	1	CLUTCH, SINGLE GROOVE, GP		
38	86350940	1	PLT, HTX CLUTCH ADAPTER		
-	86189110	-	OIL, GEN PUMP, SERIES 100		

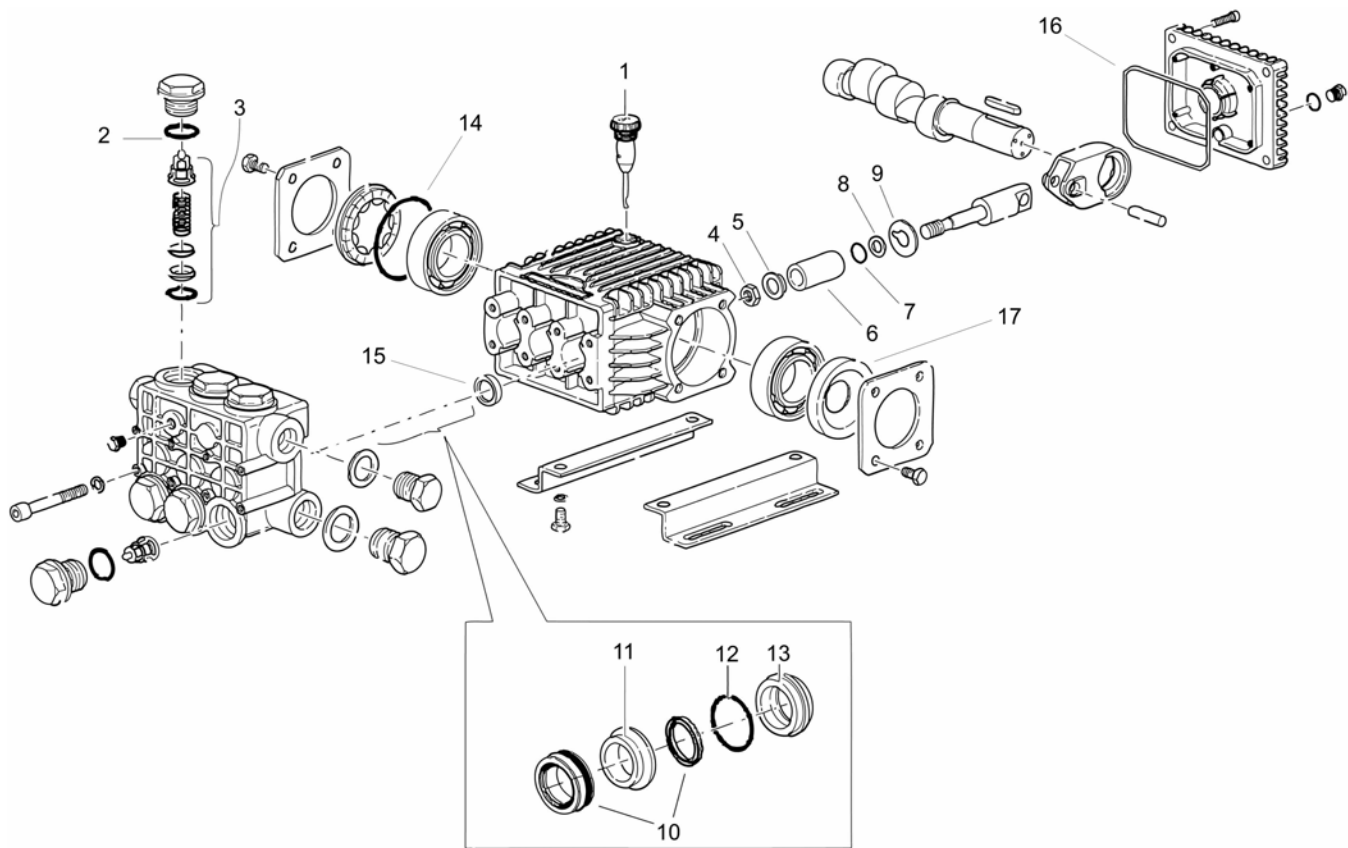

REF	PART NO.	QTY	DESCRIPTION	SERIAL NO. FROM	NOTES
-	86361360	1	PUMP, GP 3.5 GPM		
1	86315700	1	DIPSTICK, VENTED, HTX GP		
2	86315710	1	KIT, CHK VLV, HTX GP		
3	86315720	9	O-RING, VLV CAP, HTX GP		
4	86315730	3	NUT, M8, SS HTX GP		
5	86315740	3	COLLARED WASHER HTX GP		
6	86315750	3	PLUNGER, 18MM HTX GP		
7	86315760	3	O-RING, HTX GP		
8	86315770	3	ANTI-EXTRUSION RING, HTX GP		
9	86315780	3	FLINGER WASHER, HTX GP		
10	86315800	3	KIT, HP & LP SEALS, 18MM GP		
11	86315810	3	INTERMEDIATE RING, 18 MM GP		
12	86315820	3	O-RING, PLUNGER SEAL 18MM		
13	86315830	3	SEAL RETAINER, 18MM GP		
14	86361250	1	O-RING, GP PUMP HTX SIGHT		
15	86361260	3	PLUNGER, ROD OIL, SEAL		
16	86361270	1	O-RING, HTX GRP PUMP CRANKCASE		
17	86361280	1	OIL SEAL, GP HTX CRANKSHAFT		

Heat Exchanger

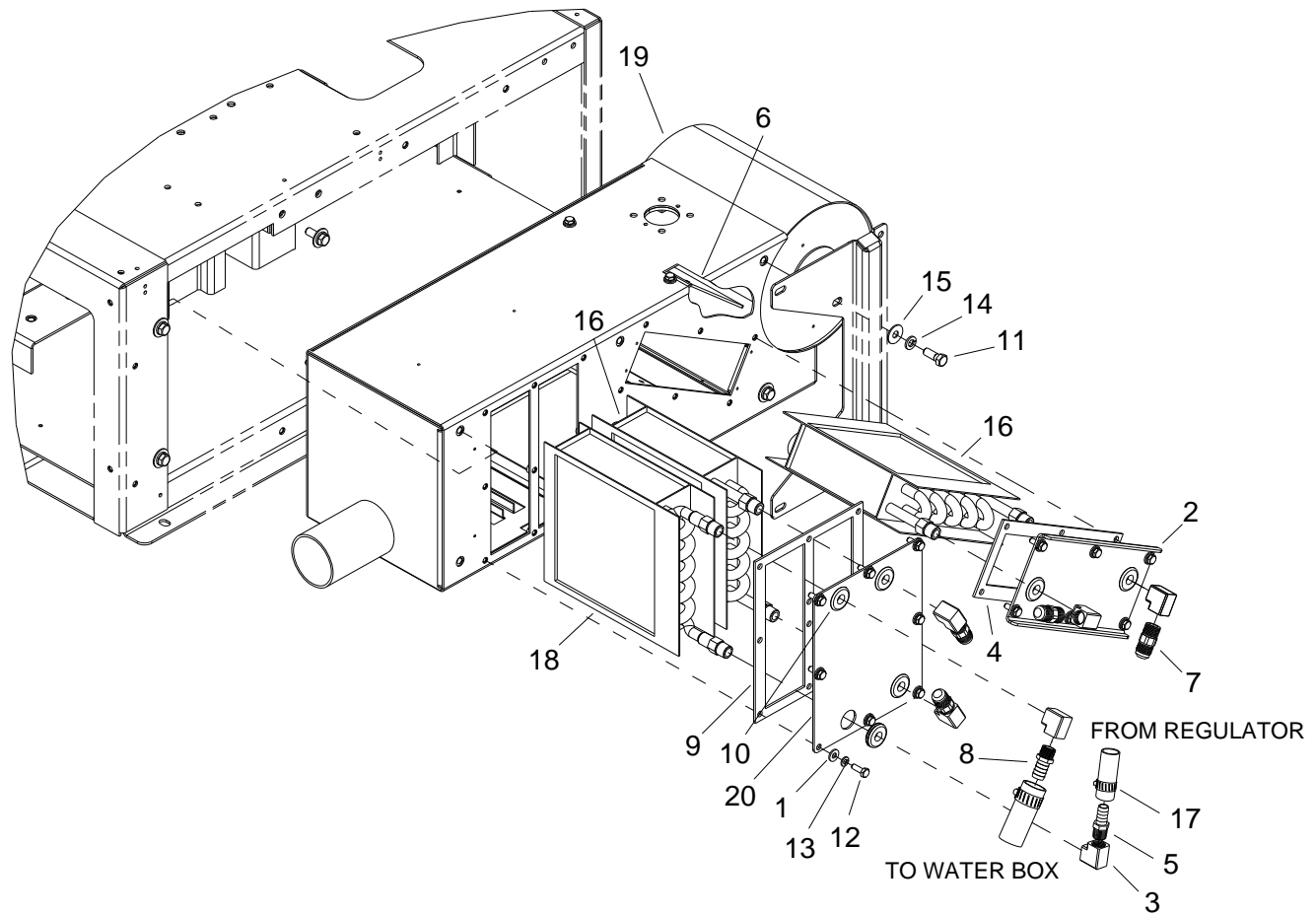

REF	PART NO.	QTY	DESCRIPTION	SERIAL NO. FROM	NOTES
1	86270330	17	FLATWASHER, 1/4		
2	86313730	1	PLATE, HEATER CORE COVER		
3	86180220	6	ELL, 3/8 BR		
4	86394270	1	GASKET, LGT 3RD CORE HE		
5	86181330	1	FTTG, BRB 3/8PX1/2H BR		
6	86310660	1	PNL, DIVERTER		
7	86177700	4	CONN, 3/8P X 1/2T BR		
8	86181400	1	FTTG, BRB 3/8P x 5/8H BR		
9	86308930	1	GASKET, HEATER CORE COVER		
10	86182190	6	GROM, 1/2 ID X 1-1/8 OD		
11	86006740	6	SCR, 3/8-16 X 1.00 HHCS GR5		
12	86274750	17	SCR, 1/4-20 X 3/4 HHCS		
13	86010780	17	WASHER, 1/4 SPLIT LOCK		
14	86010790	6	WASHER, 3/8 SPLIT LOCK		
15	86279510	6	WASHER, 3/8 X 1 FLAT NP		
16	86043150	2	ASSEMBLY, HEATER CORE SS		
17	86177260	2	CLMP,HOS#10 9/16MIN 1-1/		
18	86318840	1	ASSY, HEATER CORE COPPER, GT		
19	86308840	1	HSG, VAC HE BOX		
20	86308920	1	PLATE, HEATER CORE COVER		

Pressure Regulator & Temperature Control Valve

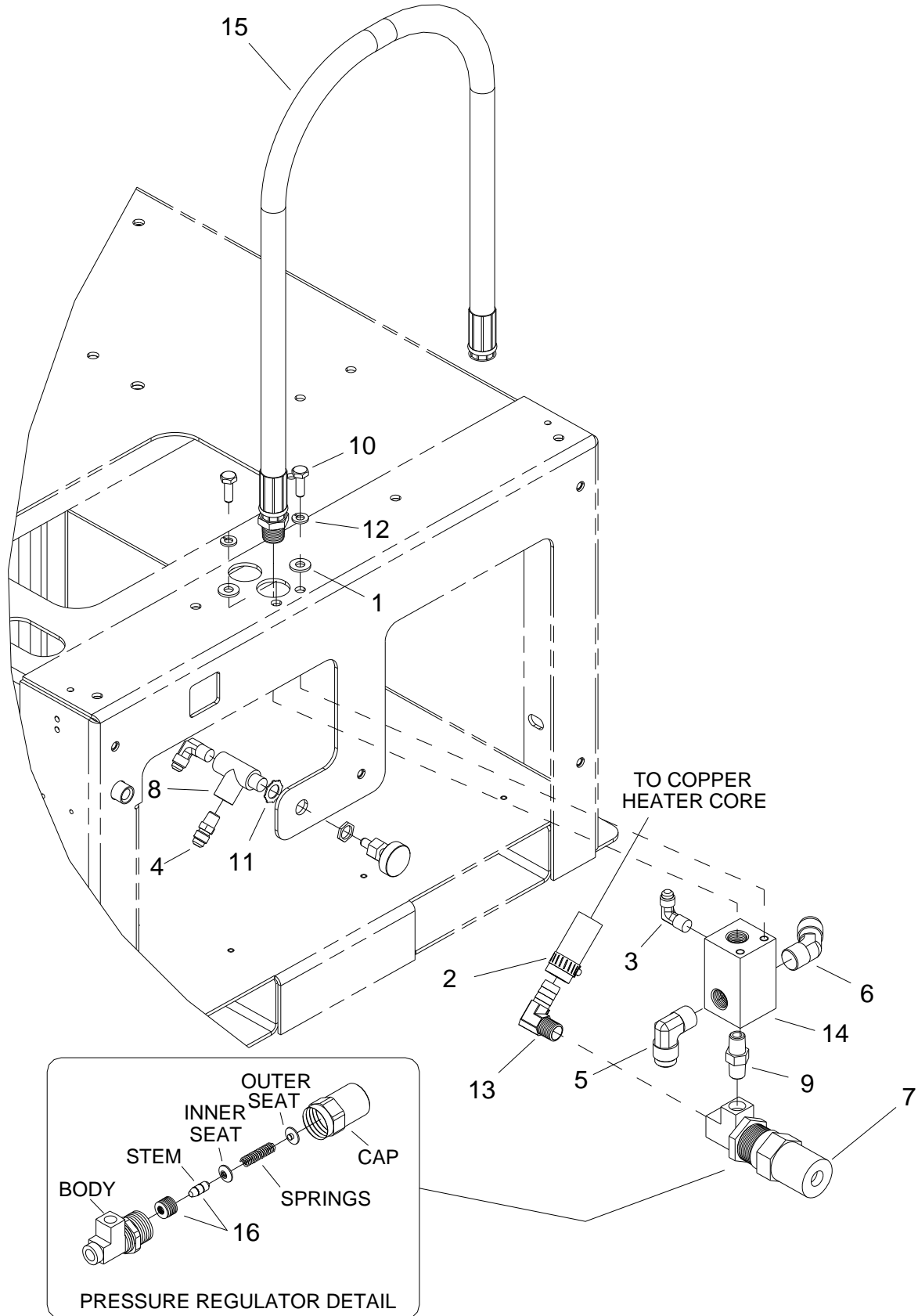

Pressure Regulator & Temperature Control Valve

REF	PART NO.	QTY	DESCRIPTION	SERIAL NO. FROM	NOTES
1	86270330	2	FLATWASHER, 1/4		
2	86177260	1	CLMP,HOS#10 9/16MIN 1-1/		
3	86180360	2	ELL, 1/8P X 1/4T BR		
4	86177660	1	CONN, 1/8P X 1/4T		
5	86180410	1	ELL, 3/8P X 1/2T BR		
6	86180450	1	ELL, 3/8P X 1/2T 45 DEG. BR		
7	86352940	1	REG. SUTT SINGL SPRG PRESS		
8	86195050	1	VALVE, METERING 1/8FP		
9	86247680	1	NIPPLE, 1/4 HEX		
10	86273780	2	SCR, 1/4-20 X 3/4 HHCS SS		
11	86278970	1	WASHER, 7/16 EXT STAR		
12	86010780	2	WASHER, 1/4 SPLIT LOCK		
13	86180040	1	ELBOW, 1/4MPX1/2H 90DEG		
14	86312440	1	MNFLD, PRESSURE REG		
15	86185180	1	HOSE, PULSE 36", 3/8 MPT BS		
16	86186040	1	KIT, REPAIR PRESSURE REG		

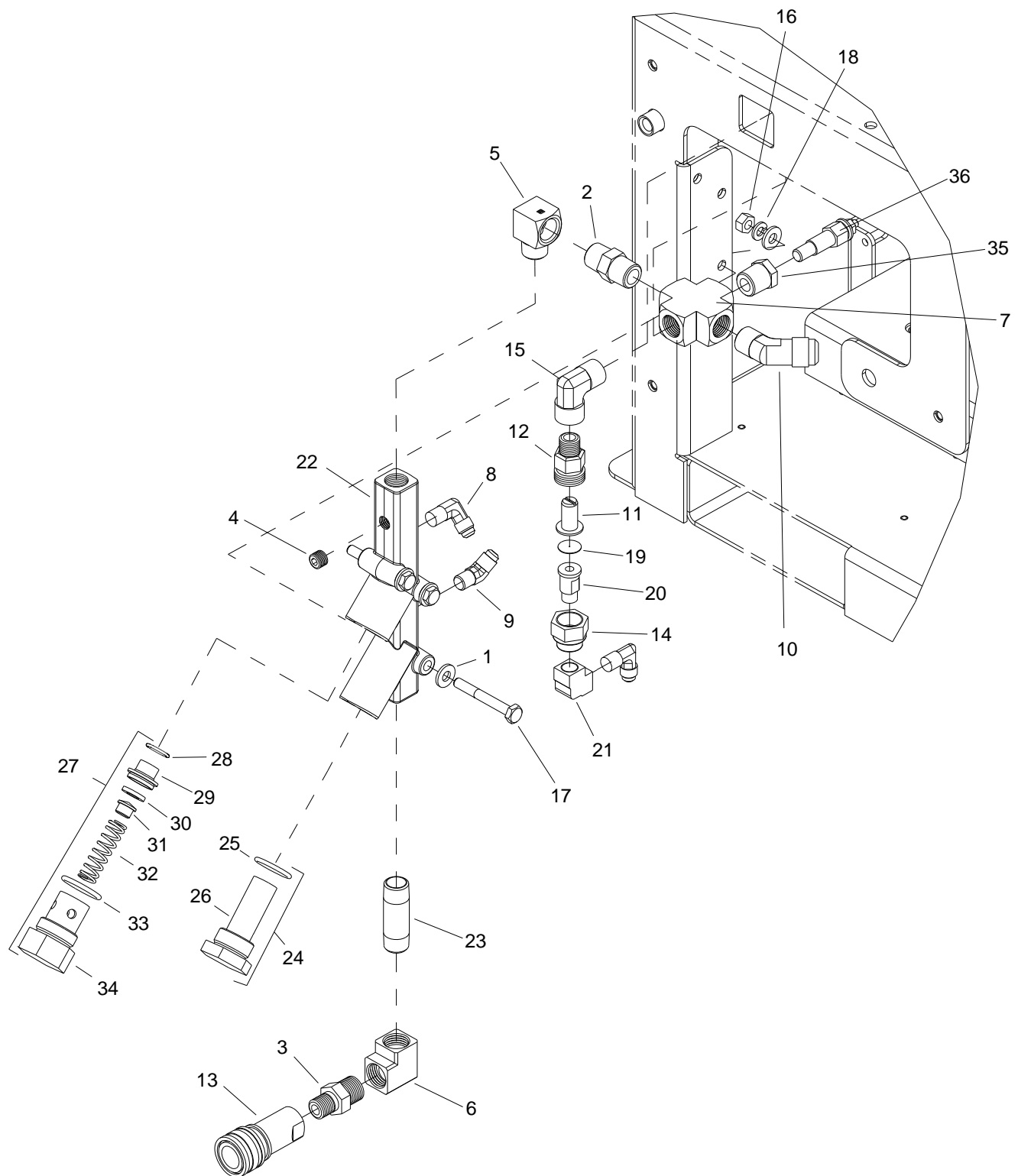

REF	PART NO.	QTY	DESCRIPTION	SERIAL NO. FROM	NOTES
1	86270330	6	FLATWASHER, 1/4		
2	86188080	1	NIP,3/8 HX BR		
3	86188130	1	NIPPLE, 3/8M X 1/4M		
4	86190180	1	PLG, 1/8 SOCHD BR		
5	86180210	1	ELL, ST 3/8 BR		
6	86180220	1	ELL, 3/8 BR		
7	86394840	1	CROSS, 3/8 FPT BRASS		
8	86180360	2	ELL, 1/8P X 1/4T BR		
9	86180420	1	ELL, 1/8P X 1/4T 45 DEG		
10	86180450	1	ELL, 3/8P X 1/2T 45 DEG. BR		
11	86193490	1	STRNR, JET 50MESH		
12	86177860	1	CONN, 1/4P X 11/16-16M		
13	86002450	1	COUPLER, 1/4 QD		
14	86002820	1	CAP, NOZZLE		
15	86197440	1	ELBOW, 3/8MPT X 1/4 FPT		
16	86270770	3	NUT, 1/4-20 HEX		
17	86273850	3	SCR, 1/4-20 X 2.00 HHCS SS		
18	86010780	3	WASHER, 1/4 SPLIT LOCK		
19	86189190	1	ORIFICE, BYPASS 4916 20 ZEEMS		
20	86173580	1	ADPTR, HOSE BYPASS		
21	86180670	1	ELL, 1/8 FEMALE NPT, BR		
22	86311640	1	ASSY, SOLUTION MANIFOLD, 6.63"		
23	86312630	1	NIPPLE, 3/8 X 2 BR		
24	86192240	1	SCRN, MESH W/O-RING, SOL MNFLD		INCLUDES 25-26
25	86189260	1	O-RING		
26	86192210	1	SCREEN, CHECK VALVE		
27	86195030	1	VALVE, CHECK		INCLUDES 28-34
28	86189230	1	O-RING		
29	86192390	1	SEAT, CHK VLV ASSY		
30	86194250	1	TEFLON SEAT		
31	86190910	1	POPPET, CHK VLV ASSY		
32	86193260	1	SPRING		
33	86189270	1	O-RING, 7/8 ID 1-1/16 OD		
34	86176350	1	CAP		
35	86175920	1	BUSH,3/8x1/8 BR		
36	86192490	1	SENDER,TEMP 140-320DEG		

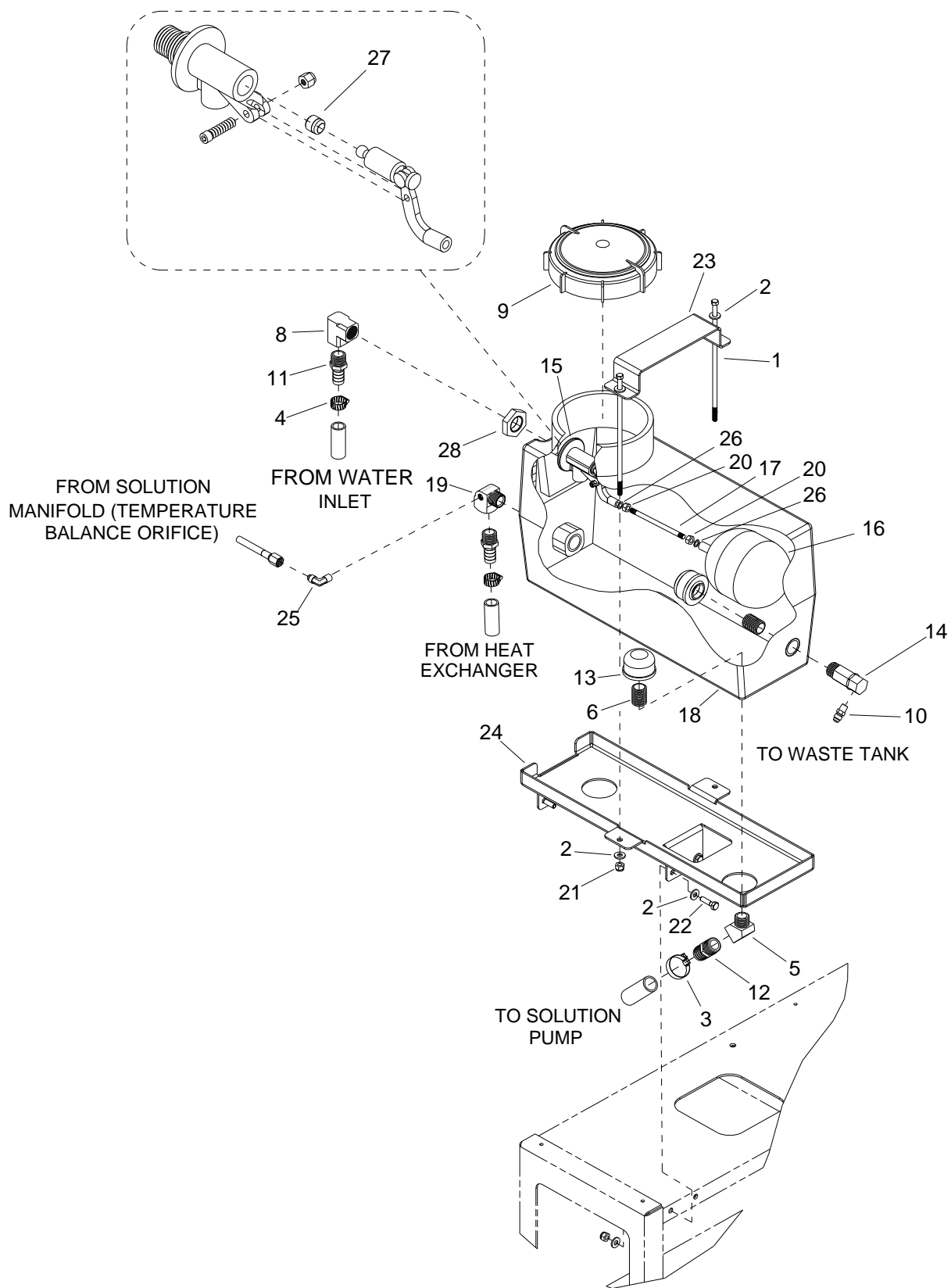

REF	PART NO.	QTY	DESCRIPTION	SERIAL NO. FROM	NOTES
1	86273410	2	SCR, CAP 1/4-20 X 8 HXHD		
2	86270330	12	FLATWASHER, 1/4		
3	86177310	1	CLMP, HOSE #16 1-1/2 MIN 1-3/4		
4	86177260	2	CLMP,HOS#10 9/16MIN 1-1/		
5	86180230	1	ELL, STREET 1/2 45 DEG		
6	86188180	2	NIP, 1/2 CL		
7	-	-	OPEN		
8	86180250	1	ELL, 1/2 BR		
9	86176400	1	CAP, WATER BOX		
10	86177660	1	CONN, 1/8P X 1/4T		
11	86181360	2	FTTG, BRB 1/2P X 5/8H BR		
12	86181370	1	FTTG, BRB 1/2P x 3/4H BR		
13	86193440	2	STRAINER, SUC END 1/2FP		
14	86195320	1	VLV, TEMP REL 165DEG		
15	86195060	1	VALVE, FLOAT, TM		
16	86348200	1	BALL, 4" DIA X 5" L, WHITE FLOAT		
17	86181150	1	ROD, FLOAT 1/4-20 X 6" SS		
18	86187820	1	MOLDING, WATER BOX		
19	86317520	1	EL, STRT 1/2MP X 1/2FP W/ 1/8FP		
20	86270770	2	NUT, 1/4-20 HEX		
21	86005680	6	NUT, 1/4-20 HEX NYLOCK		
22	86274750	4	SCR, 1/4-20 X 3/4 HHCS PLTD		
23	86308940	1	BRKT, WTR BOX HOLDDOWN		
24	86309000	1	BRKT, WTR BOX MTG		
25	86180360	1	ELL, 1/8P X 1/4T BR		
26	86010660	2	WASHER 1/4 LOCK EXT STAR SS		
27	86192380	1	SEAT FLOAT VALVE TM		
28	86189010	1	NUT, FLOAT VALVE		

60 Gallon Waste Tank

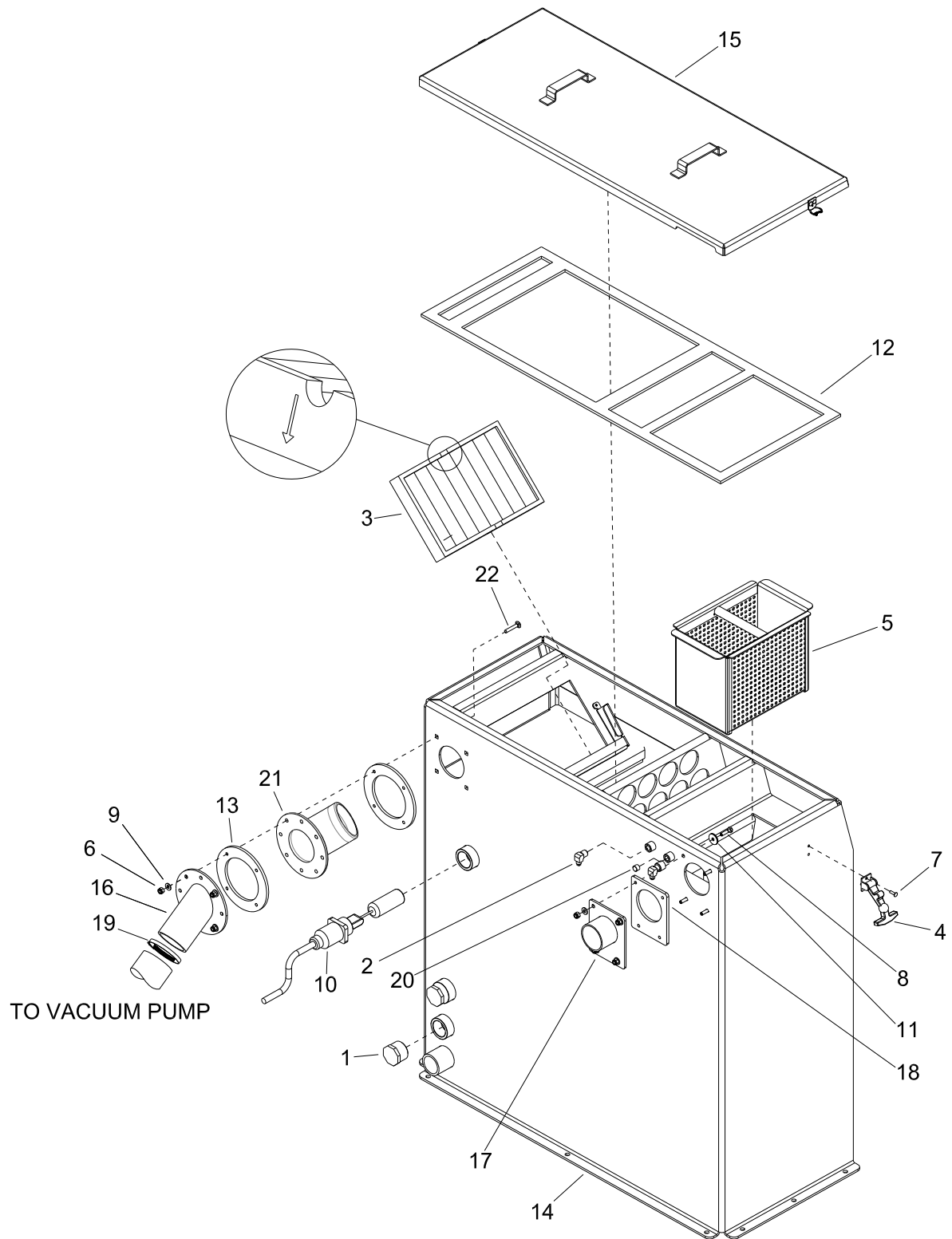

REF	PART NO.	QTY	DESCRIPTION	SERIAL NO. FROM	NOTES
-	98408770	1	KIT, WASTE TANK 60G LGT/BGT PC		COMPLETE
1	86190530	2	PLUG, 1-1/4 HXHD PVC		
2	86180340	2	ELL, 1/4P X 1/4T BR		
3	86193540	1	STRNR, WST TNK, RECT, 1.5		
4	86186860	2	LATCH, DRAW 2-7/8 SST		
5	86043190	1	STRAINER BOWL, AVENGER 450		
6	86005810	8	NUT, 1/4-20 HEX NYLOCK SS		
7	86273020	8	RIVET, 3/16 OD X 5/8 AL		
8	86273810	4	SCR, 1/4-20 X 1 HHCS SS		
9	86010630	8	WASHER, 1/4 X 5/8 FLAT SS		
10	86193870	1	ASSY, LVL SENS SHTOF SW		
11	86202240	4	WASHER, SEAL 1/4 X 1 OD SS		
12	86318530	1	GASKET, WASTE TANK LID		
13	86318560	2	GASKET, VAC OUTLET		
14	86410200	1	TANK, WASTE, 60G PC		
15	86410190	1	LID, WST TNK, 60G PC		
16	86412520	1	OUTLET, VACUUM, 2-7/8", PC, GRY		
17	86412530	1	INLET, 2-1/2" VACUUM, PC, GRY		
18	86323700	1	GASKET, VAC INLET		
19	86177010	1	CLAMP, HOSE #48		
20	86272720	1	PLG, 1/4 SOCHD BRASS		
21	86415330	1	ELBOW, Ø3.50 OD X 53°		
22	86277000	4	SCREW, 1/4-20 X 1.5 CARR SS		
-	86264850	-	ADH,GSKT (ADHESIVE)		

100 Gallon Waste Tank

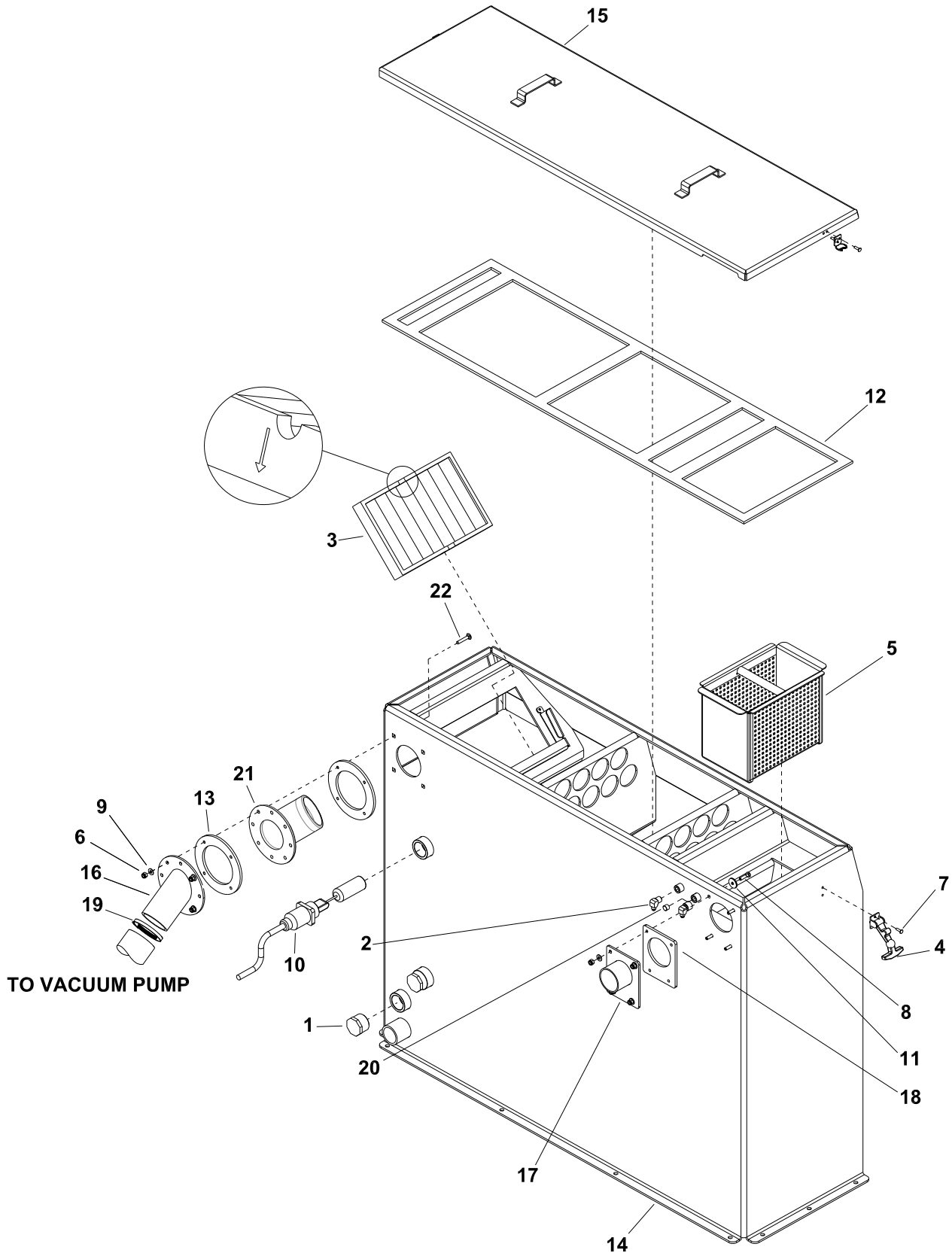

REF	PART NO.	QTY	DESCRIPTION	SERIAL NO. FROM	NOTES
-	98408780	1	KIT, WASTE TANK 100G LGT/BGT PC		COMPLETE
1	86190530	2	PLUG, 1-1/4 HXHD PVC		
2	86180340	2	ELL, 1/4P X 1/4T BR		
3	86193540	1	STRNR, WST TNK, RECT, 1.5		
4	86186860	2	LATCH, DRAW 2-7/8 SST		
5	86043190	1	STRAINER BOWL, AVENGER 450		
6	86005810	8	NUT, 1/4-20 HEX NYLOCK SS		
7	86273020	8	RIVET, 3/16 OD X 5/8 AL		
8	86273810	4	SCR, 1/4-20 X 1 HHCS SS		
9	86010630	8	WASHER, 1/4 X 5/8 FLAT SS		
10	86193870	1	ASSY, LVL SENS SHTOF SW		
11	86202240	4	WASHER, SEAL 1/4 X 1 OD SS		
12	86325770	1	GASKET, 100G LID WST TNK		
13	86318560	2	GASKET, VAC OUTLET		
14	86410180	1	TANK, WASTE, 100G PC		
15	86410170	1	LID, 100G WST TNK, PC		
16	86412520	1	OUTLET, VACUUM, 2-7/8", PC, GRY		
17	86412530	1	INLET, 2-1/2" VACUUM, PC, GRY		
18	86323700	1	GASKET, VAC INLET		
19	86177010	1	CLAMP, HOSE #48		
20	86272720	1	PLG, 1/4 SOCHD BRASS		
21	86415330	1	ELBOW, Ø3.50 OD X 53°		
22	86277000	4	SCREW, 1/4-20 X 1.5 CARR SS		
-	86264850	-	ADH,GSKT (ADHESIVE)		

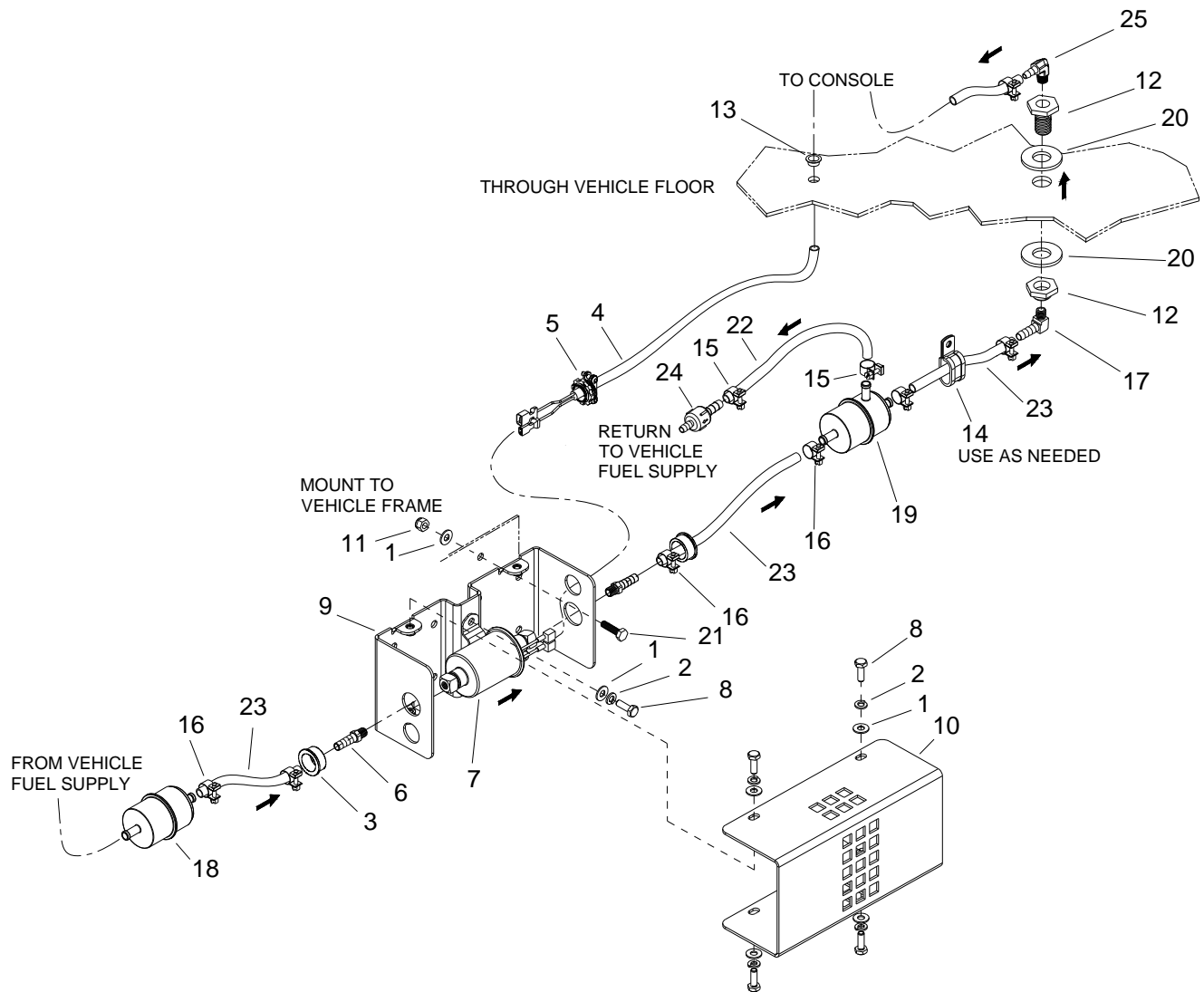

REF	PART NO.	QTY	DESCRIPTION	SERIAL NO. FROM	NOTES
1	86010630	14	WASHER, 1/4 ID X 5/8 OD SS		
2	86173340	6	WASHER, SPLIT LOCK, 1/4, SS		
3	86175970	2	BUSHING, SNAP HEYCO 2140		
4	86176930	1	CD, FUEL PUMP, 2003 VAN		
5	86177880	1	CONN, CORD 1/2		
6	86181300	2	FTTG, BARB 1/8P X 5/16H		
7	86191420	1	PUMP, FUEL AIRTEX		
8	86273780	6	SCR, 1/4-20 X 3/4 HHCS SS NP		
9	86335230	1	HOUSING, FUEL PUMP		
10	86335240	1	COVER, FUEL PUMP		
11	86005810	4	NUT, 1/4-20 HEX NYLOCK SS		
12	86175850	1	BULKHEAD		
13	86175980	1	BUSH, OPEN/CLSD 5/8 HOL		
14	86177370	4	CLMP, FUEL LINE 5/16 X 1/4B		
15	86177390	2	CLAMP, F.I., SAE 12, 1/4" HOSE		
16	86177400	7	CLAMP, F.I., SAE 14, 5/16" HOSE		
17	86179920	1	EL, 90DEG 1/8 X 5/16HB		
18	86180960	1	FILTER, FUEL, 5/16		
19	86181620	1	FUEL FILTER		
20	86182460	2	GSKT, BULKHD-FUEL LINE HKU		
21	86273810	4	SCR, 1/4-20 X 1 HHCS SS		
22	86282410	1	HOSE, FUEL 1/4 X 6'		
23	86184980	1	HOSE, 5/16" FUEL X 12', T-FLEX		
24	86339630	1	VALVE, CHECK, 1/4H X 5/16H FUEL		
25	86179930	1	EL, 90DEG 1/8NPT X 1/4HB		
-	86282810	2	SLEEVE, 3/4 LOOM X 23"		
-	86265730	10	TIE, CABL 8" WHT		
-	86273290	4	SCR, SLFDR #14 X 1 HXHD		

Battery Floor Mount

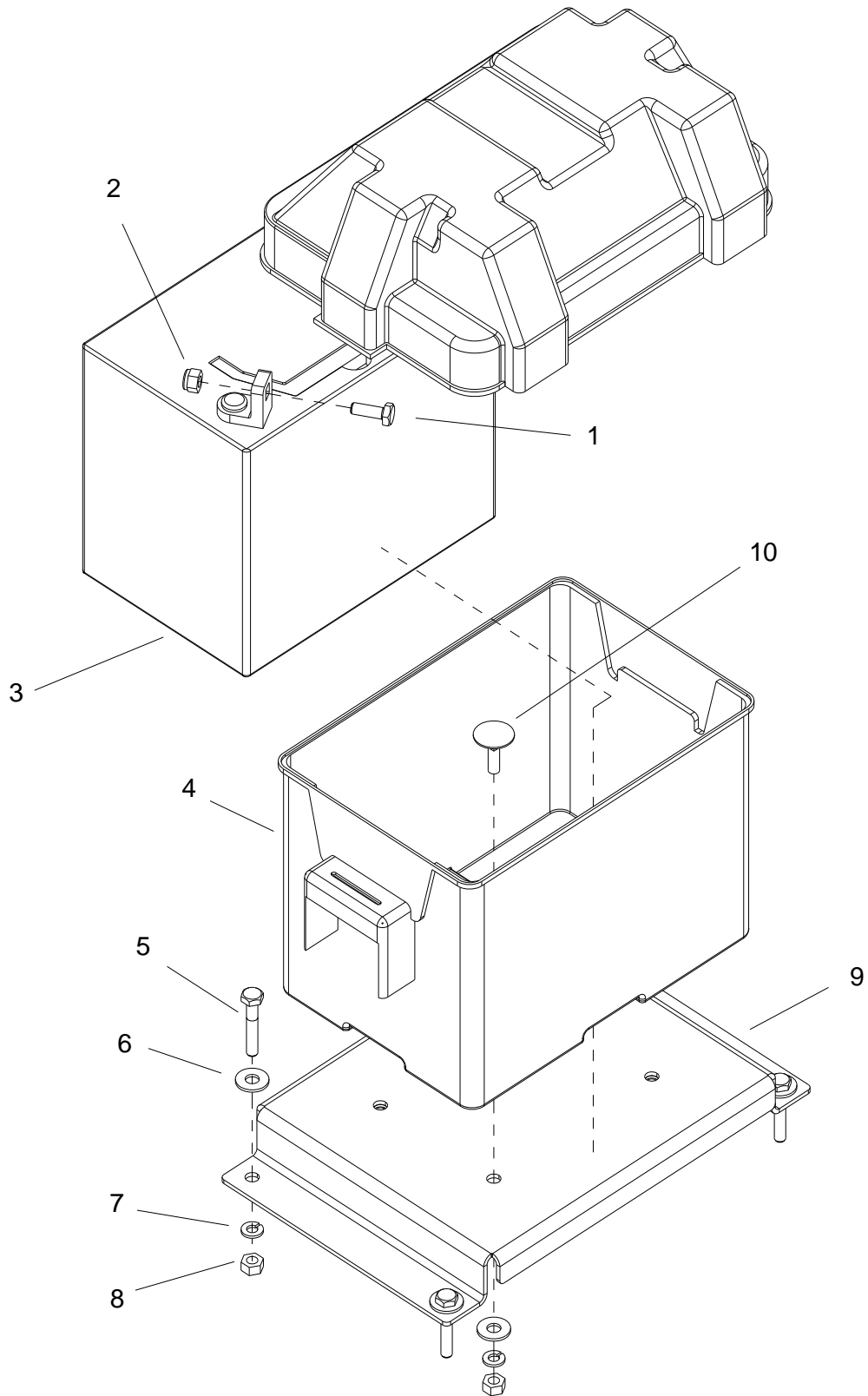

REF	PART NO.	QTY	DESCRIPTION	SERIAL NO. FROM	NOTES
-	86030550	1	KIT,BAT FLR MTG TM		COMPLETE EXCLUDING BATTERY
1	86273780	2	SCR, 1/4-20 X 3/4 HHCS SS NP		
2	86005680	2	NUT, 1/4-20 HEX NYLOCK		
3	86174580	1	BATTERY		
4	86012060	1	BOX, BATTERY, MODIFIED		
5	86273190	4	SCR, 1/4-20 X 1-1/2 HXHD		
6	86270330	8	FLATWASHER, 1/4		
7	86010780	8	WASHER, 1/4 SPLIT LOCK PLTD		
8	86270770	8	NUT, 1/4-20 HEX		
9	86309890	1	BRKT, BATTERY BOX MTG		
10	86011470	4	BOLT, ELEVATOR, 1/4-20 X 1		

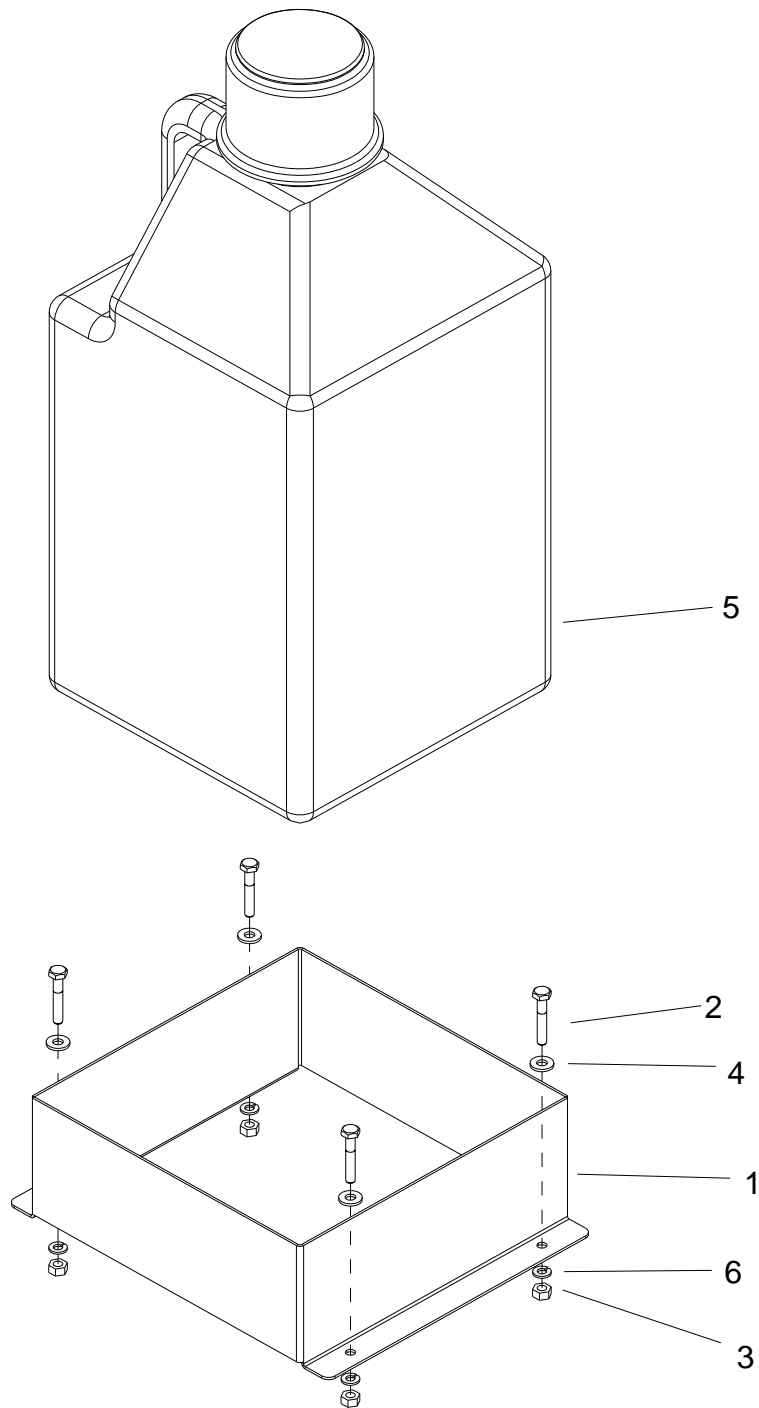

REF	PART NO.	QTY	DESCRIPTION	SERIAL NO. FROM	NOTES
1	86298250	1	HOLDER, 5 GAL JUG		
2	86273190	4	SCR, 1/4-20 X 1-1/2 HXHD		
3	86270770	4	NUT, 1/4-20 HEX		
4	86270330	4	FLATWASHER, 1/4		
5	86185720	1	JUG,5 GAL, SINGLE HNDL, WHITE		
6	86010780	4	WASHER 1/4 SPLIT LOCK PLTD		

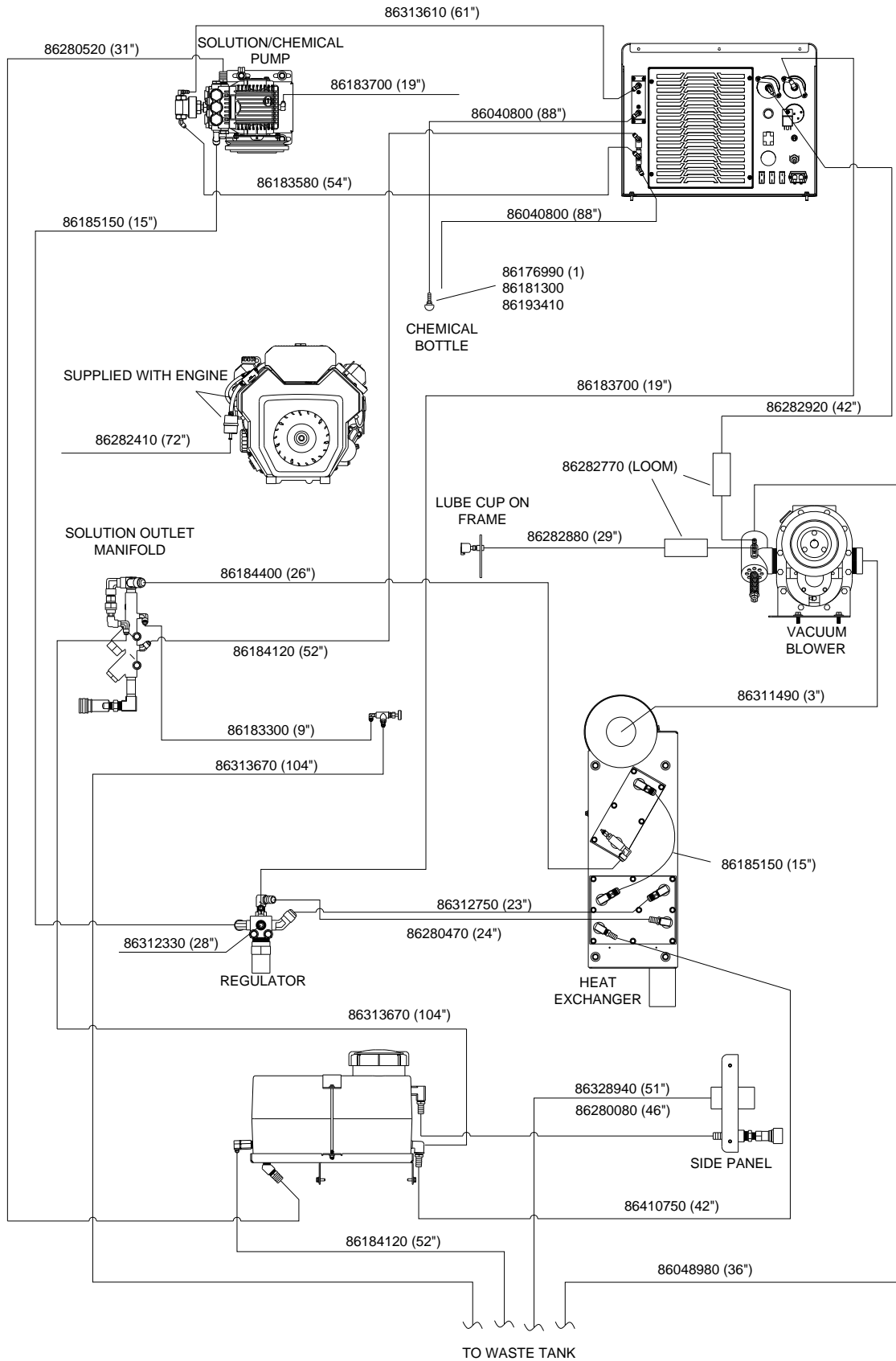

Notes:

OPTIONS

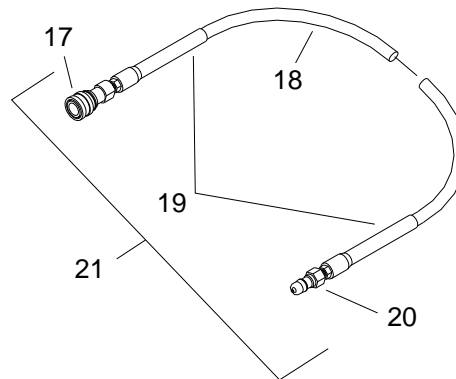
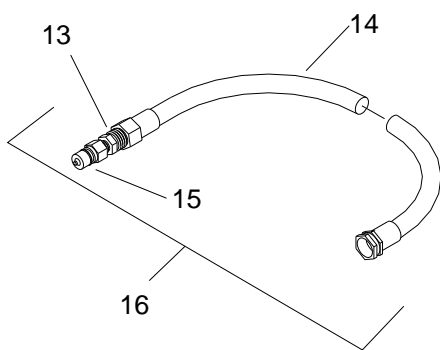
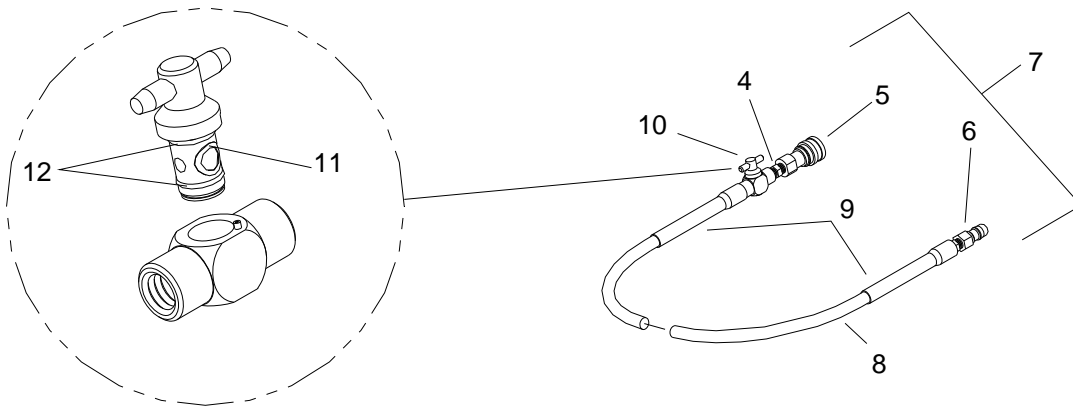
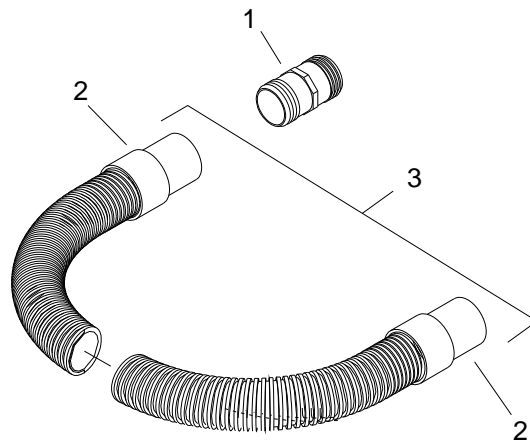

REF	PART NO.	QTY	DESCRIPTION	SERIAL NO. FROM	NOTES
1	86180980	1	FITTING, BRB 2H BS PVC		
2	86178640	2	CUFF, 2"		
3	86184510	1	HOSE, VAC 2"X50' W/ CUFFS & HOSE		
4	86247680	1	NIPPLE, 1/4 HEX		
5	86002450	1	COUPLER, 1/4 QD		
6	86005580	1	NIPPLE, 1/4 FPT QD		
7	86184530	1	HOSE, HP 1/4 X 50FT W/QD & VLVE		
8	86184520	1	HOSE, HP 1/4 X 50'		
9	86182800	2	GUARD, HOSE VINYL		
10	86194990	1	VALVE, BALL 1/4FP		
11	86189240	2	O-RING, 7/32ID X 11/32OD		
12	86189250	2	O-RING, 3/8 ID X 1/2 OD		
13	86188210	1	NIP, 1/2 X 3/8 HEX BR		
14	86184570	1	HOSE, WATER 1/2 X 50'		
15	86179630	1	DISCONNECT 3/8M X 3/8FP		
16	86410660	1	HOSE, 1/2" ID X 50' BLK W/QD		
17	86002450	1	COUPLER, 1/4 QD		
18	86184520	1	HOSE, HP 1/4 X 50'		
19	86182800	2	GUARD, HOSE VINYL		
20	86005580	1	NIPPLE, 1/4 FPT QD		
21	86184540	1	HOSE, HP 1/4 X 50FT W/QD		

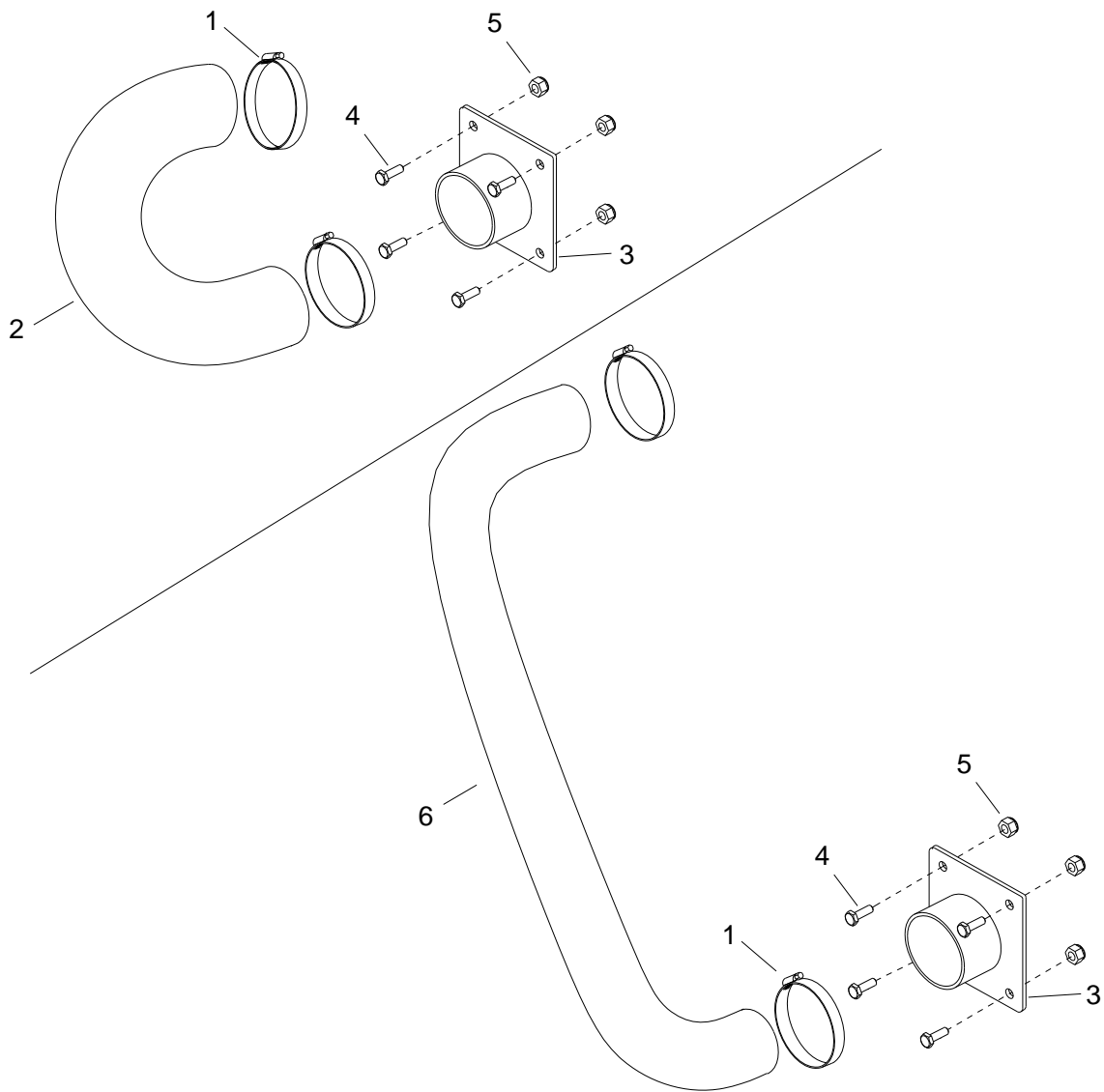

REF	PART NO.	QTY	DESCRIPTION	SERIAL NO. FROM	NOTES
1	86177010	2	CLAMP, #48 HOSE		
2	86280600	1	HOSE, 3" X 17" FLEXABLE		
3	86181110	1	FLANGE, VAC EXH DUCT KIT LG		
4	86192060	4	SCREW, 1/4-20 X 1-1/4" SST		
5	86005810	4	NUT, 1/4-20 HEX NYLOCK SS		
6	86335340	1	HOSE, 3" ID, FLX EXHST X 36"		
-	86030440	1	KIT, EXHAUST 3"ID, SINGLE		KIT COMPLETE
-	86335350	1	KIT, EXHAUST 3" ID, SINGLE, AUX TNK		KIT COMPLETE

Automatic Pumpout - Dual Diaphragm - Optional

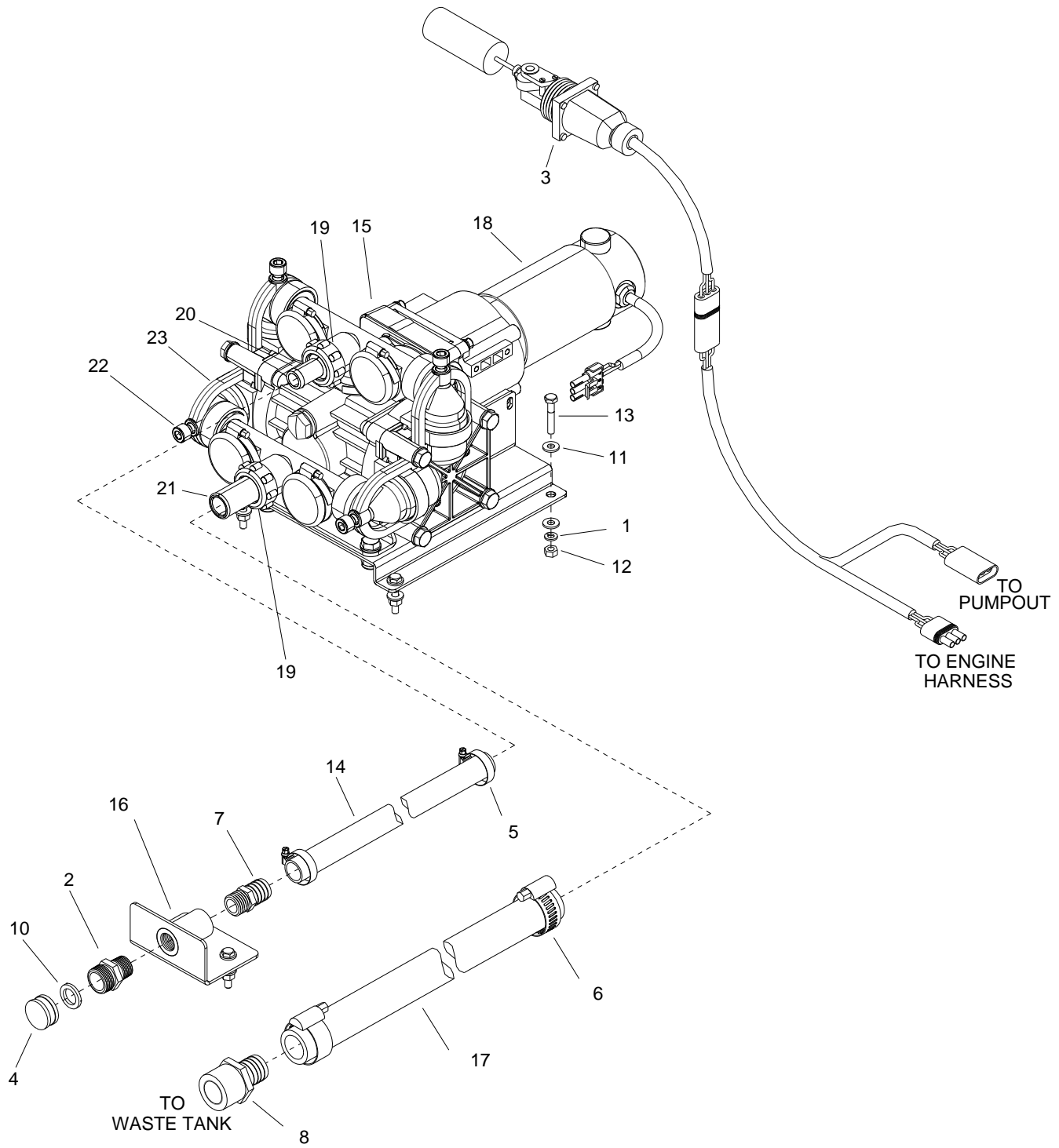

Automatic Pumpout - Dual Diaphragm - Optional

REF	PART NO.	QTY	DESCRIPTION	SERIAL NO. FROM	NOTES
-	86335970	1	ASSY, PUMPOUT, DUAL DIAPHRAGM		COMPLETE ASSEMBLY
1	86010780	1	WASHER, 1/4 SPLIT LOCK, PLTD		
2	86173530	1	ADAPTER, HOSE 1/2M X 3/4 MGT		
3	86174260	1	ASSY, LVL SW WASTE PUMPOUT		
4	86176420	1	CAP,HOS 3/4 BR		
5	86177310	2	CLMP, HOSE #16 1-1/2 MIN 1-3/4		
6	86177050	2	CLAMP, HOSE #20		
7	86181370	1	FTTG, BRB 1/2P X 3/4H BR		
8	86181440	1	FTTG, 1-1/4P X 1"H BR		
9	86336420	4	CLAMP, DUAL PUMPOUT		
10	86195820	1	WSR,HOS 5/8 ID 1"OD		
11	86270330	12	FLATWASHER, 1/4		
12	86270770	6	NUT, 1/4-20 HEX		
13	86273190	6	SCR, 1/4-20 X 1-1/2 HXHD		
14	86280590	1	HOSE, 3/4ID WTR X 96"		
15	86333880	1	PUMPOUT, WASTE, DUAL DIAPHRAGM		
16	86335950	1	BRKT, HOSE CONNECTING		
17	86335960	1	HOSE, 1" ID X 18" BLACK EXHAUST		
18	86336370	1	MOTOR, BISON PUMP 12V		
19	86336350	2	NUT, 3/4"DIA OUTLET, DUAL PUMPOUT		
20	86336360	1	FTTG, BARB, 3/4"DIA, DUAL PUMPOUT		
21	86336380	1	FTTG, BARB, OUTLET, DUAL PUMPOUT		
22	86336410	4	SCR, CLAMP SHCS, DUAL PUMPOUT		
-	86184780	1	HOSE, GARDEN 3/4 X 75'		NOT SHOWN
-	86336300	2	DIAPHRAGM, PUMP OUT, DUAL		NOT SHOWN
-	86336310	2	BOLT, DIAPH RETAINING		NOT SHOWN
-	86336320	2	WASHER, DIAPH RETAINING		NOT SHOWN
-	86336340	4	VALVE, DUAL PUMPOUT, CHECK		NOT SHOWN
-	86336390	4	O-RING, DUAL PUMPOUT, MANIFOLD		NOT SHOWN
-	86336400	2	O-RING, BARB FTTG, DUAL PUMPOUT		NOT SHOWN
-	86336440	1	KIT, DUAL PUMPOUT, REBUILD		NOT SHOWN

Wand - Titanium Six Jet - Optional

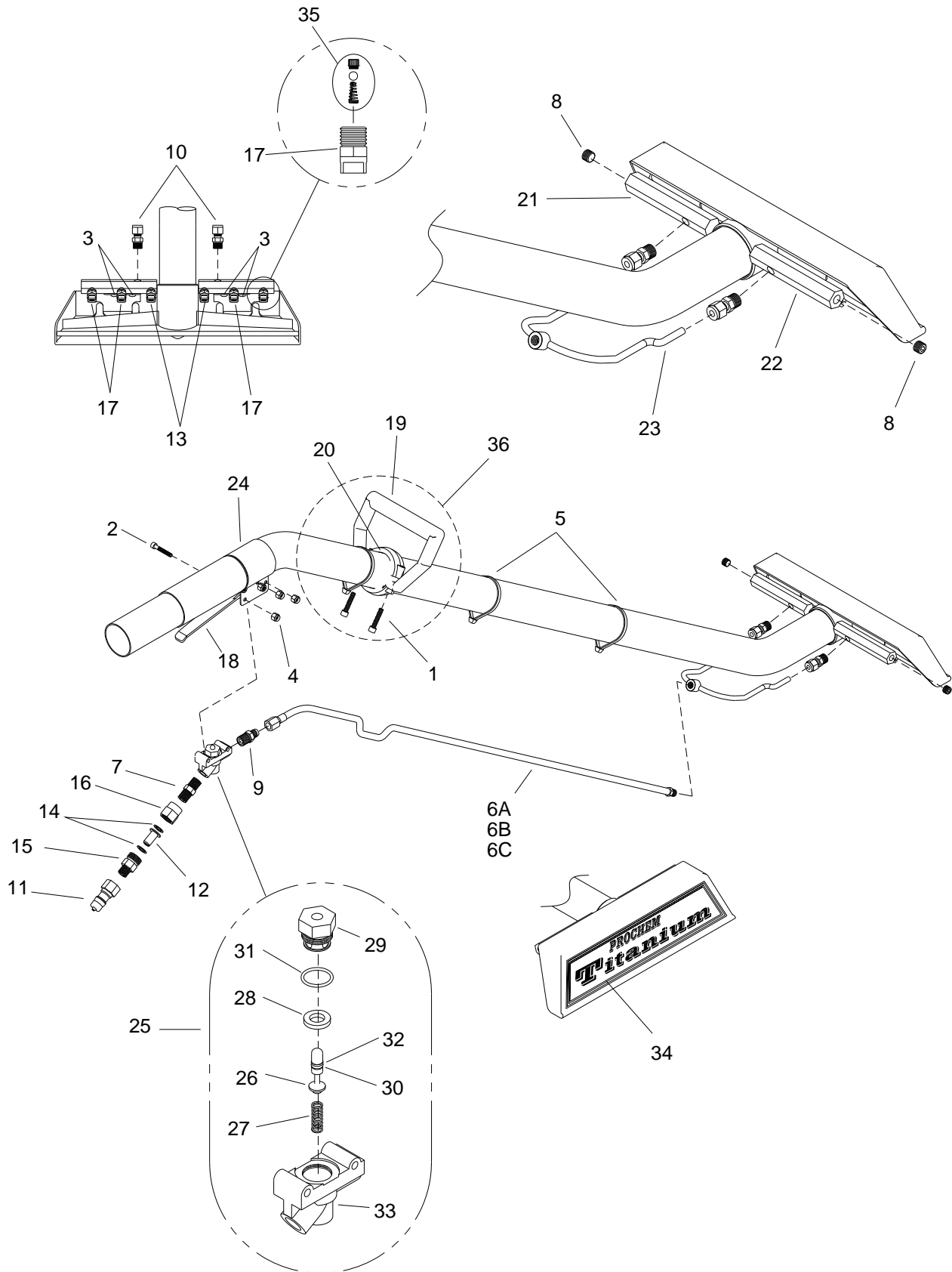

REF	PART NO.	QTY	DESCRIPTION	SERIAL NO. FROM	NOTES
-	86288350	1	WD, TM, 6 JET, TITANIUM (8001) PC		COMPLETE
1	86273310	2	SCR, CAP 1/4-20 X 1 1/4 SOC		
2	86192030	4	SCR, CAP 10-32 X 1 1/4 SOCH		
3	86006680	4	SCR, 10-32 X 1/4 PPHMS SS		
4	86270990	4	NUT, 10-32 HEX NYLOCK SS		
5	86264910	2	TIE, CABLE 13"		
6A	86184270	1	HOSE, 3/16 X 46 (1/8P X 1/4FT) MET		▲
6B	86337360	1	HOSE, 3/16 X 47 (1/8P X 1/4FT) MET		▲
6C	86183720	1	HOSE, 3/16 X 47 5/8 (1/8P X 1/4FT) MET		▲
7	86247680	1	NIPPLE, 1/4 HEX		
8	86190180	2	PLUG, 1/8 SOCHD BR		
9	86177650	1	CONN, 1/4P X 1/4T BR		
10	86177710	2	CONN, 1/8P X 1/4T COMP BR		
11	86005580	1	NIPPLE, 1/4 FPT QD		
12	86193490	1	STRAINER, JET 50 MESH		
13	86194450	2	TIP, SPRAY 9501 X 1/8P SST		
14	86195570	2	WASHER, NYLON		
15	86177860	1	CONN, 1/4P X 11/16-16M		
16	86177870	1	CONN, 1/4FP X 11/16-16F BR		
17	86194580	4	TIP, SPRAY 8001 SST \1/8 VJET		
18	86340720	1	TRIGGER, WD VLV, 9 DEG		
19	86174680	1	BODY, WD HDL, 2" TB, BK		
20	86198180	1	HOLD DN-WD HDL 2" TUBE		
21	86187610	1	MANFOLD, LEFT		
22	86187620	1	MANIFOLD, RIGHT		
23	86174060	1	ASSY, MNFLD S-BEND		
24	86372970	1	BRACKET, WAND VALVE		
25	86174120	1	ASSY, EXTRACTOR VALVE		
26	86193360	1	STEM, EXTRACTOR VALVE		
27	86193200	1	SPRING, EXTRACTOR VALVE		
28	86192410	1	SEAT, EXTRACTOR VALVE		
29	86183160	1	HLDR, VLV STEM-EXTRACTOR VL		
30	86189510	1	O-RING, .114 ID .254OD		
31	86189520	1	O-RING, .551ID .691OD		
32	86174500	1	BACK-UP, .250DIA		
33	86174630	1	BDY, EXTRACTOR VLV		
34	86179250	1	DEC, WD HD TITANIUM		
35	86341590	6	CHECK VALVE, NOZZLE WD		
36	86182850	1	HANDLE GRIP ASSEMBLY 2.0"		INCLUDES ITEMS 1, 19, 20

▲ MEASURE AND MATCH EXISTING HOSE LENGTH.

REF	PART NO.	QTY	DESCRIPTION	SERIAL NO. FROM	NOTES
-	86326900	1	WAND, ERGO TI		COMPLETE
1	86195560	1	WAND/HEAD WELDMENT		
2A	86182820	1	GUN, PRESS WASH TM		
2B	86011740	1	YG5000 SPRAY GUN ASM		
3	86188590	1	NIPPLE, 1/4 X 5 SS		
4	86175760	1	BRKT, HNDL, CLMP		
5	86277760	2	SCR, 8-32 X 1/4 SHCS SS		
6	86188280	1	NIP, 3/8 X 1/4 HX SST		
7	86177870	1	CONN, 1/4FP X 11/16-16F BR		
8	86193490	1	STRNR, JET 50 MESH		
9	86177860	1	CONN, 1/4 X 11/16-16M		
10	86005580	1	NIP, 1/4 FPT QD		
11	86195600	1	WASHER, BLK WD		
12	86195610	1	WASHER, FLAT SS WD		
13	86179020	1	DEC, WD HD (CAST SST) TM		
14	86177650	1	CONN, 1/4P X 1/4T BR		
15	86031580	1	HOSE, 3/16 X 40-1/2		
16	86183110	1	HDL, TITANIUM WND W/SPYR		
17	86182120	1	GRIP, BLK HANDLE		
18	86177150	2	CLAMP, #38 HOSE SS		
19	86194450	2	TIP, SPRY 9501 X 1/8P SST		
20	86270990	4	NUT, 10-32 HEX SS NYLOCK		
21	86194580	4	TIP, SPRAY 8001 SST 1/8 VJE		
22	86187620	1	MNFLD, LT TITAN		
23	86177710	2	CONN, 1/8P X 1/4T COMP BR		
24	86187610	1	MNFLD, RT TITAN		
25	86190180	2	PLG, 1/8 SOCHD BR		
26	86175660	1	BRKT, MANIFOLD, WAND		
27	86341590	6	CHECK VALVE, NOZZLE WD		
-	86186100	1	KIT, REPAIR 17-803025		

Wand - Quad Jet - Optional

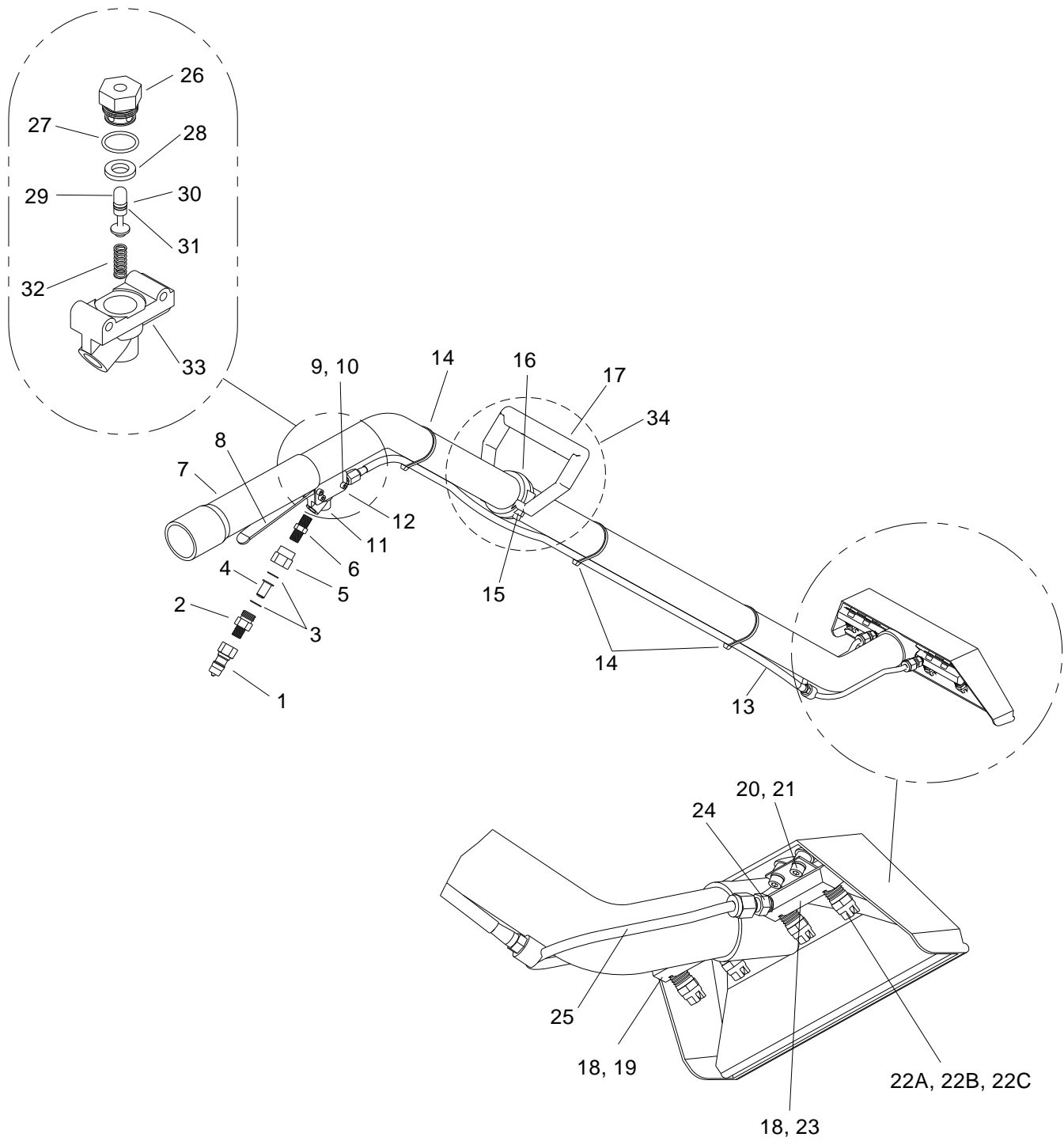

REF	PART NO.	QTY	DESCRIPTION	SERIAL NO. FROM	NOTES
-	86285570	-	WAND, TM, QJW (95015) PC		COMPLETE
-	86285580	-	WAND, TM, QJW (9502) PC		COMPLETE
-	86285560	-	WAND, TM QJW (9501) PC		COMPLETE
-	86285540	-	WAND, TM, QJW, (9501) NO DECAL		COMPLETE
1	86005580	-	NIPPLE, 1/4 FPT QD		
2	86177860	1	CONN, 1/4P X 11/16-16M		
3	86195570	1	WASHER, NYLON		
4	86193490	2	STRAINER, JET 50 MESH		
5	86177870	1	CONN, 1/4FP,11/16-16R BR		
6	86247680	1	NIPPLE, 1/4 HEX		
7	86280020	1	SLEEVE, WD HDL 9.5		
8	86194650	1	TRIGGER, WD VLV		
9	86192030	3	SCR, CAP 10-32X 1-1/4 SOCH		
10	86270990	3	NUT, 10-32 HEX NYLOCK SS		
11	86174120	1	ASSY, EXTRCTR VLV		
12	86177650	1	CONN, 1/4P X 1/4T BR		
13	86183970	1	HOSE, 3/16 X 43-1/2 (1/8P X 1/4)		
14	86265730	3	TIE, CABLE 8" WHT		
15	86273310	2	SCR, CAP 1/4-20 X 1-1/4 SOC		
16	86198160	1	HOLD DOWN, WD HDL		
17	86182840	1	BODY, WD HDL		
18	86190180	2	PLUG, 1/8 SOCHD BR		
19	86043300	1	ASSY, L S-BEND MNFLD		
20	86273450	4	SCR, CAP 10-24 X1/4 SOCHD		
21	86279470	4	WASHER, #10 SPLIT LOCK		
22A	86194400	4	TIP, SPRY 95015X1/8P SST		89238
22B	86194410	4	TIP, SPRY 9502X1/8P SST		89239
22C	86194450	4	TIP, SPRY 9501X1/8P SST		89237 89235 (NO DECAL)
23	86043310	1	ASSY, RT S-BEND MNFLD		
24	86177710	2	CONN, 1/8PX1/4T COMP BR		
25	86174030	1	ASSY, S-BEND MNFLD		
26	86183160	1	HOLDER, VLV STEM-EXTRCTR VL		
27	86189520	1	O-RING, .551 ID .691 OD		
28	86192410	1	SEAT, EXTRCTR VLV		
29	86193360	1	STEM, EXTRCTR VLV		
30	86174500	1	BACK-UP, .250 DIA		
31	86189510	1	O-RING, .144 ID .254 OD		
32	86193200	1	SPRING, EXTRCTR VLV		
33	86174630	1	BODY, EXTRCTR VLV		
34	86182840	1	HANDLE GRIP ASSEMBLY 1.75"		INCLUDES PARTS 15, 16, 17
-	86179020	1	DECAL, WD HD (CAST SS)		
-	86186160	-	KIT, REP-WD VLV		INCLUDES PARTS 26-32

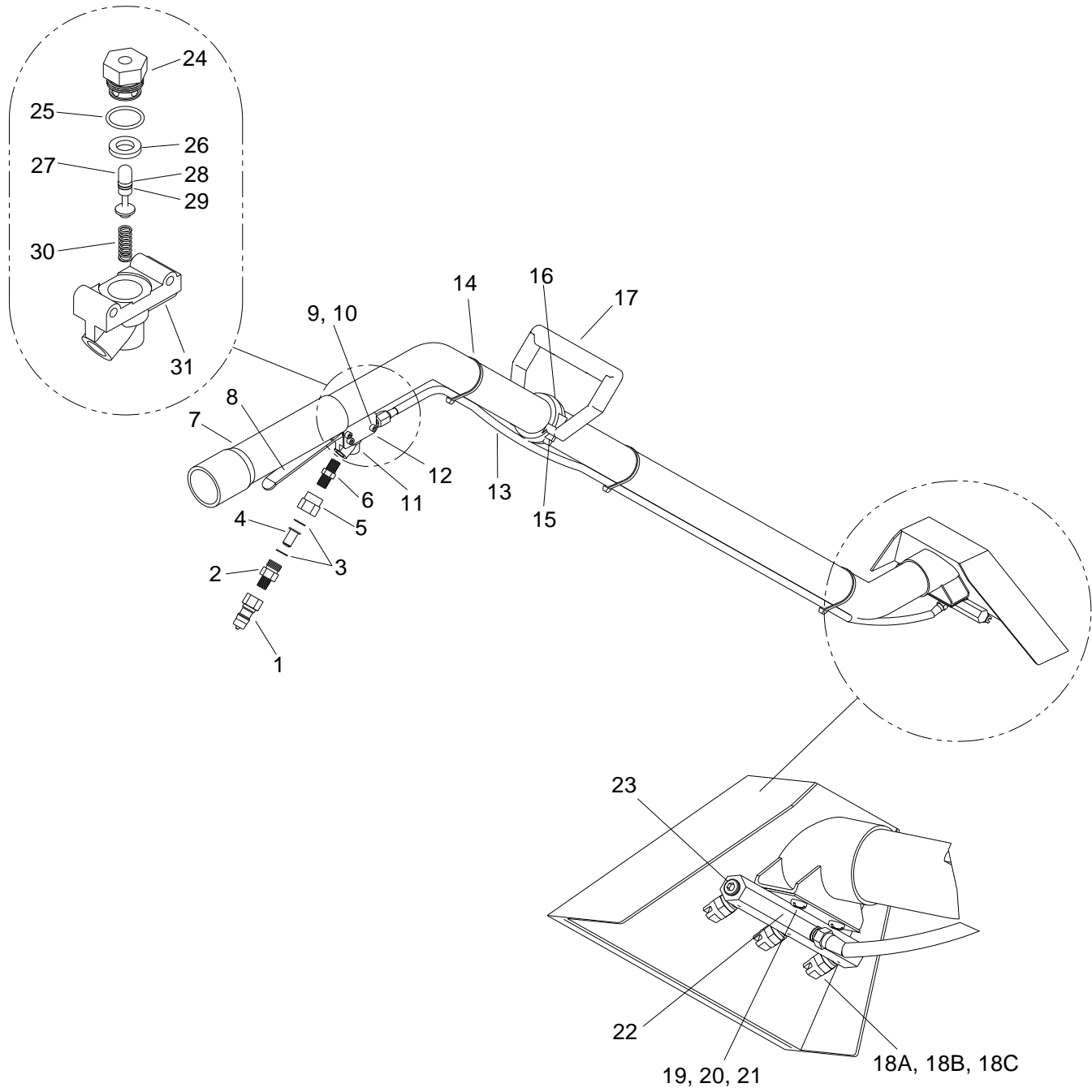

REF	PART NO.	QTY	DESCRIPTION	SERIAL NO. FROM	NOTES
-	86285520	-	WAND, TJW (9502) PC		COMPLETE
-	86285510	-	WAND, TJW, (95015) CUBXL		COMPLETE
-	86285530	-	WAND, TJW, (9503) PC		COMPLETE
1	86005580	1	NIPPLE, 1/4 FPT QD		
2	86177860	1	CONN, 1/4P X 11/16-16M		
3	86195570	2	WASHER, NYLON		
4	86193490	1	STRAINER, JET 50MESH		
5	86177870	1	CONN, 1/4FP, 11/16-16R BR		
6	86247680	1	NIPPLE, 1/4 HEX		
7	86280020	1	SLEEVE, WD HDL 9.5		
8	86194650	1	TRIGGER, WD VLV		
9	86192030	3	SCR, CAP 10-32X 1-1/4 SOCH		
10	86270990	3	NUT, 10-32 HEX NYLOCK SS		
11	86174120	1	ASSY, EXTRCTR VLV		
12	86177650	1	CONN, 1/4P X 1/4T BR		
13	86183970	1	HOSE, 3/16X49 (1/8P X 1/4FT)		
14	86265730	3	TIE, CABLE 8" WHT		
15	86273310	1	SCR, CAP 1/4-20 X 1-1/4 SOC		
16	86198160	1	HOLD DOWN, WD HDL		
17	86182840	1	BODY, WD HDL		
18A	86194410	3	TIP, SPRY 9502X1/8P SST		89233
18B	86194400	3	TIP, SPRY 9501X1/8P SST		89232
18C	86194520	3	TIP, SPRY 9503X1/8P SST		89234
19	86274290	2	SCR, 10-32 X 3/8 PPHMS SS		
20	86279470	2	WASHER, #10 SPLIT LOCK		
21	86270800	2	NUT, 10-32 HEX SS		
22	86187700	1	MANIFOLD, WD TRI-JET		
23	86190180	2	PLUG, 1/8 SOCHD BR		
24	86183160	1	HOLDER, VLV STEM-EXTRCTR VL		
25	86189520	1	O-RING, .551 ID .691 OD		
26	86192410	1	SEAT, EXTRCTR VLV		
27	86193360	1	STEM, EXTRCT VLV		
28	86174500	1	BACK-UP, .250DIA		
29	86189510	1	O-RING, .114ID .254OD		
30	86193200	1	SPRING, EXTRCTR VLV		
31	86179020	1	BODY, EXTRCTR VLV		
-	86179020	-	DECAL, WD HD		
-	86186160	-	KIT, REP-WD VLV		INCLUDES PARTS 24-30

Stair Tool - Optional

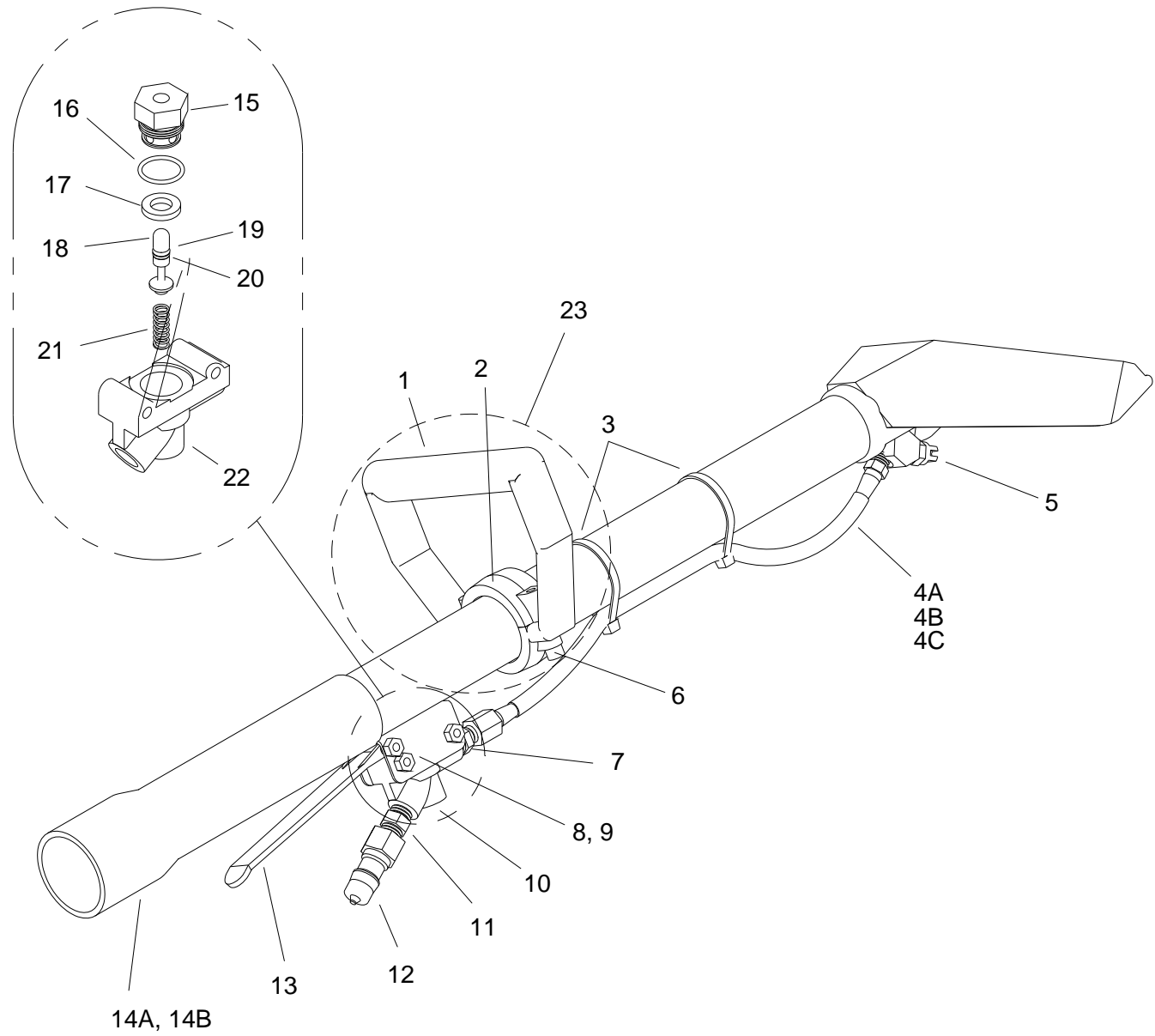

REF	PART NO.	QTY	DESCRIPTION	SERIAL NO. FROM	NOTES
-	86285350	-	TL, STAIR, LNG, TM DJ (80015)		COMPLETE
-	86285290	-	TL, STAIR, SHT, TM (80015)		COMPLETE
1	86198080	1	BODY, WD HDL PORT		
2	86198170	1	HOLD DOWN, WD HDL PORT		
3	86265730	2	TIE, CABLE 8" WHT		
4A	86183710	1	HOSE, 3/16X13-3/4 (1/8PX1/4)		
4B	86184000	1	HOSE, 3/16X7-1/2 (1/8P X 1/4F)		
4C	86356140	1	HOSE, 3/16 X 9 (1/8PX1/4FT)MET		
5	86194410	1	TIP, SPRY 9502X1/8P SST		
6	86273310	2	SCR, CAP 1/4-20 X 1-1/4 SOC		
7	86177650	1	CONN, 1/4P X 1/4T BR		
8	86192030	3	SCR, CAP 10-32X1-1/4 SOCH		
9	86270990	3	NUT, 10-32 HEX NYLOCK SS		
10	86174120	1	ASSY, EXTRCTR VLV		
11	86247680	1	NIPPLE, 1/4 HEX		
12	86005580	1	NIPPLE, 1/4 FPT QD		
13	86194650	1	TRIGGER, WD VLV		
14A	86280020	1	SLEEVE, WD HDL 9.5		
14B	86040950	1	SLEEVE, STAIR TL HDL 7-1/8		
15	86183160	1	HOLDER, VLV STEM-EXTRCTR VL		
16	86189520	1	O-RING, .551 ID .691 OD		
17	86192410	1	SEAT, EXTRCTR VLV		
18	86193360	1	STEM, EXTRCTR VLV		
19	86174500	1	BACK-UP, .250DIA		
20	86189510	1	O-RING, .114 ID .254 OD		
21	86193200	1	SPRING, EXTRCTR VLV		
22	86174630		BODY, EXTRCTR VLV		
23	86135760	1	HANDLE GRIP ASSEMBLY 1.5"		INCLUDES PARTS 1, 2, 6
-	86178970		DECAL, STAIR TL		
-	86186160		KIT, REP-WD VLV		INCLUDES PARTS 15-21
-	86178480	-	CPLG,UPHLST TL HOS (COUPLER)		

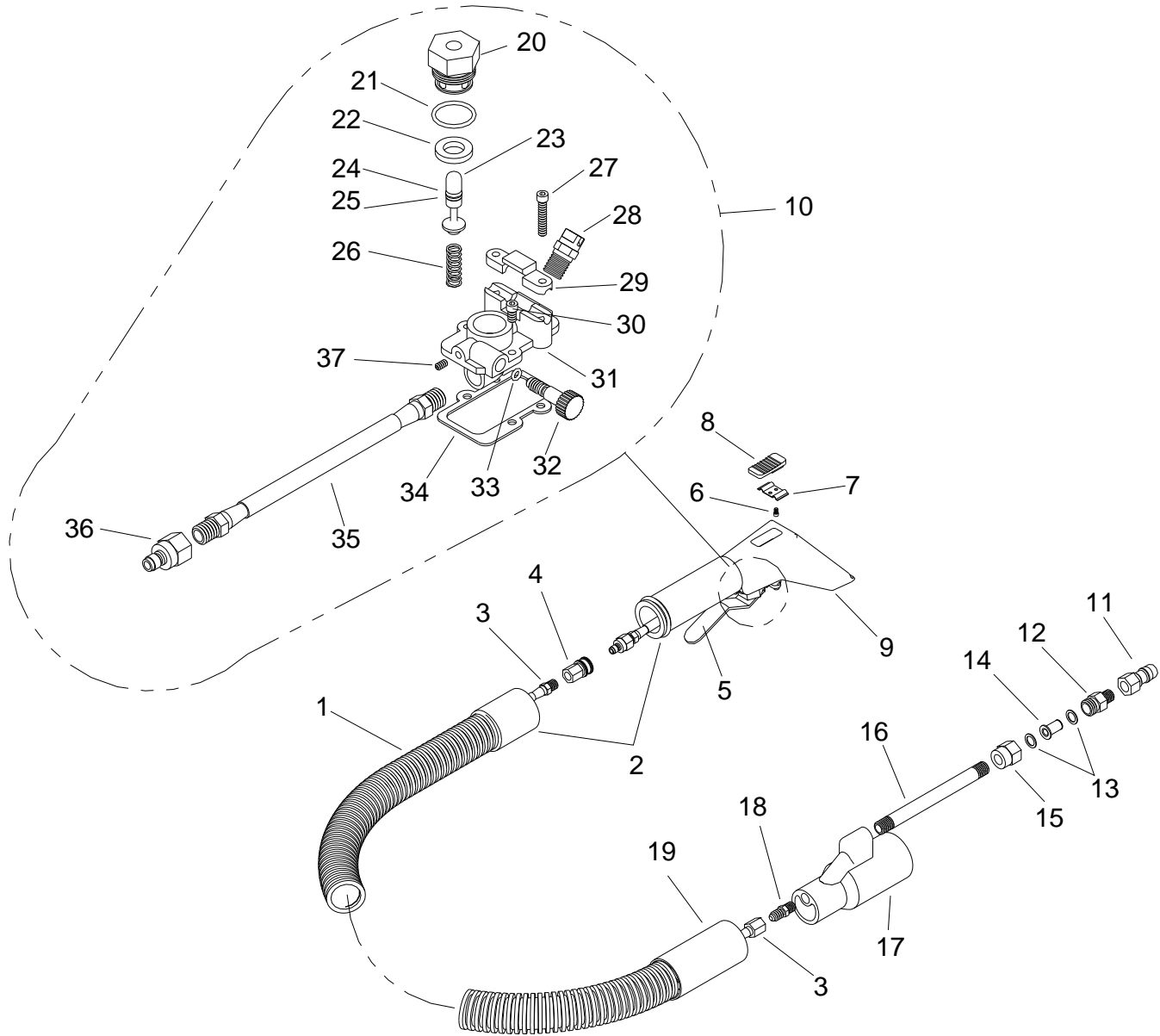

REF	PART NO.	QTY	DESCRIPTION	SERIAL NO. FROM	NOTES
-	86285260	1	TL, UPHOLST, PC (80015)		COMPLETE
1	86280240	2	HOSE, VAC 1-1/4X10'		
2	86178660	1	CUFF, SWIV 1-1/4HX1-1/4T		
3	86184670	1	HOSE, 3/16X119-1/2 (1/8PX1/4FT)		
4	86179720	1	DSC, 1/8FC1/8FP SST		
5	86178550	1	UPHOLSTERY TL TRIGGER		
6	86273370	1	SCR, CAP 4-40 X7/32 SHCS SS		
7	86193050	1	SPRING, VAC ADJ BUTT		
8	86176080	1	BUTTON, VAC ADJ		
9	86194590	1	TOOL, UPHOLSTERY		
10	86174140	1	ASSY, UPHLST TL VLV		INCLUDES PARTS 20-26, 28, & 31- 37
11	86005580	1	NIPPLE, 1/4 NPT QD		
12	86177860	1	CONN, 1/4P X 11/16-16M		
13	86195570	1	WASHER, NYLON		
14	86193490	1	STRAINER, JET 50MESH		
15	86177870	1	CONN, 1/4FPX11/16-16F BR		
16	86188320	1	NIP, 1/4X5 SST		
17	86178520	1	COUPLER, UPHLST TL		
18	86177660	1	CONN, 1/8P X 1/4T		
19	86178630	1	CUFF, 1 1/4H X 1 1/2T GRY		
20	86183160	1	HOLDER, VLV STEM-EXTRCTR VL		
21	86189520	1	O-RING, .551 ID .691 OD		
22	86192410	1	SEAT, EXTRCTR VLV		
23	86193360	1	STEM, EXTRCTR VLV		
24	86174500	1	BACK-UP, 250DIA		
25	86189510	1	O-RING, .144 ID .254 OD		
26	86193200	1	SPRING, EXTRCTR VLV		
27	86273350	2	SCR, 6-32 X 1 SCHD SS		
28	86194500	1	TIP, SPRY 80015X1/8P SST		
29	86178540	1	CSTG, TRIGGER CLMP		
30	86273360	2	SCR, CAP 6-32X3/8 SOCHD		
31	86195210	1	VALVE, UPHLST TL		
32	86195530	1	VALVE, ADJ-UPHLST TL VLV		
33	86189460	1	O-RING, 5/32IDX9/32OD VIT		
34	86182570	1	GASKET, UPHLST TL VLV		
35	86183770	1	HOSE, 3/16X6-1/2 (1/8P BS)		
36	86179740	1	D SC, 1/8MX1/8FP SST		
37	86192070	1	SCR, SET 3-32 X 1/4 SOCHD		
-	86178980	1	DECAL, UPHLST TL		
-	86186160	1	KIT, REPAIR-WAND VLV		INCLUDES PARTS 20-26

Shelf Assembly - Optional

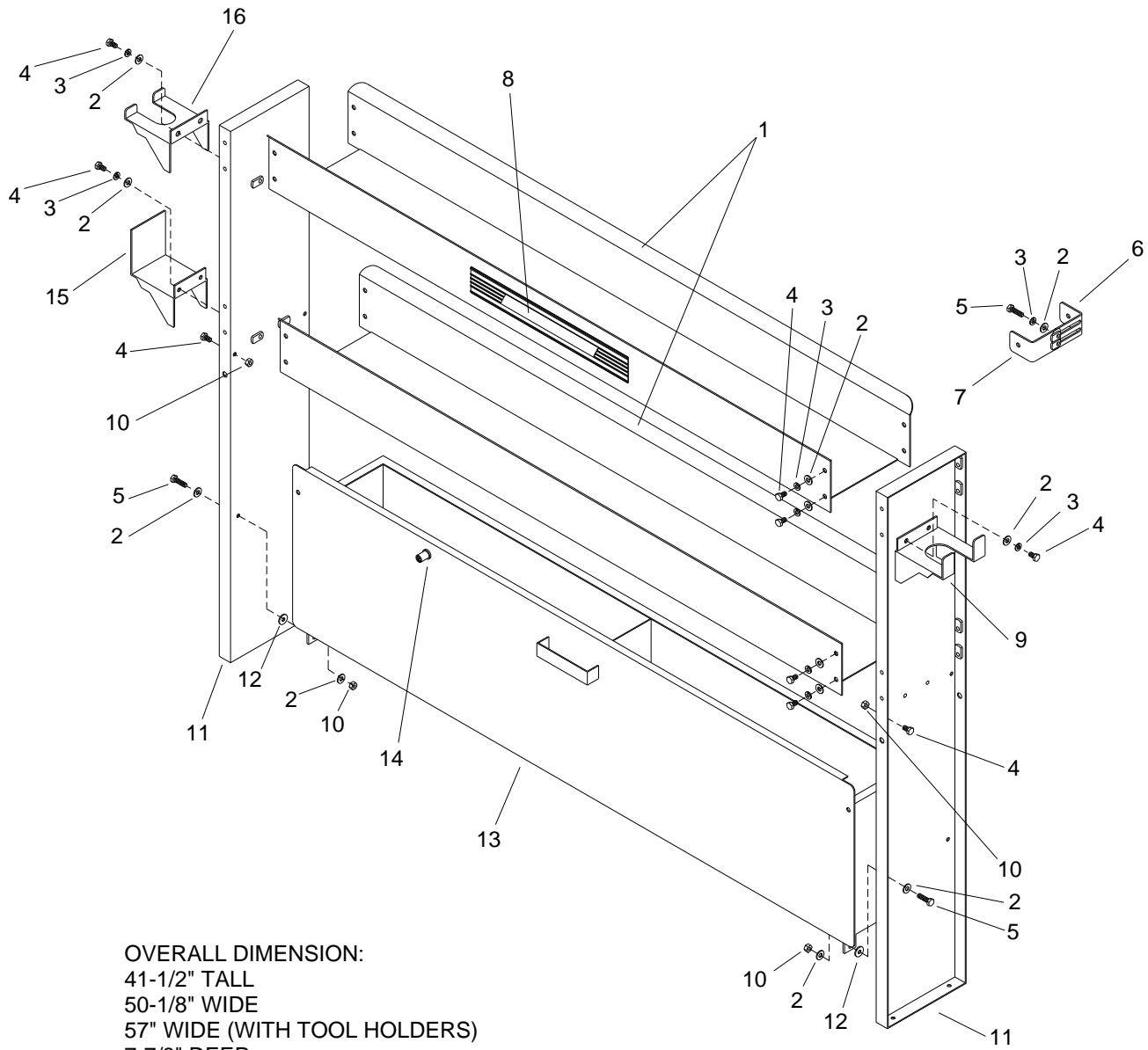

OVERALL DIMENSION:
 41-1/2" TALL
 50-1/8" WIDE
 57" WIDE (WITH TOOL HOLDERS)
 7-7/8" DEEP

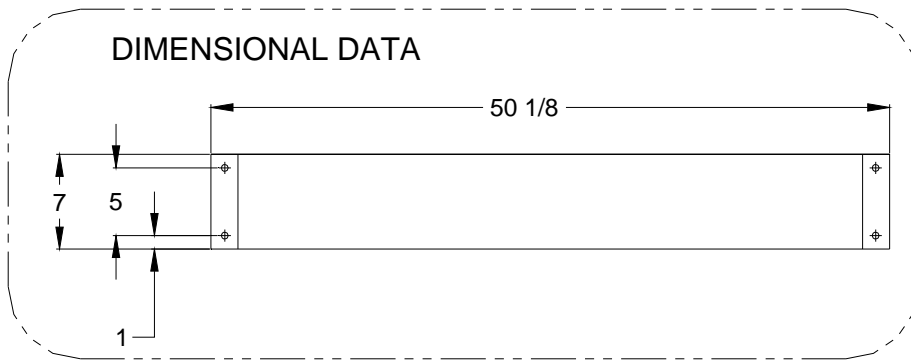

REF	PART NO.	QTY	DESCRIPTION	SERIAL NO. FROM	NOTES
-	86354970	1	ASM, VAN STORAGE UNIT		COMPLETE
1	86363820	2	SHELF, LOWER TM		
2	86270330	20	FLATWASHER, 1/4		
3	86010780	20	WASHER, 1/4 SPLIT LOCK		
4	86274760	20	SCR, 1/4-20 X 1/2 HHCS PLTD		
5	86274750	4	SCR, 1/4-20 X 3/4 HHCS PLTD		
6	86398940	2	BRACKET, SLOTTED SHELF ASSY		
7	86175730	2	BRKT, ADJUST MTG HLDR		
8	86410010	1	LABEL, PROCHEM		
9	86363850	1	HLDR, STAIR TL		
10	86270620	4	LOCK NUT, 1/4-20 HXHD		
11	86024890	2	PANEL, SHLF END		
12	86278840	2	WASHER, NYLON		
13	86024900	1	DRAWER, SHELF GRAY		
14	86186850	1	LATCH, ADJ GRIP		
15	86363840	1	HLDR, UP TL HOS		
16	86363830	1	HLDR, UPHLST TL		

Water Tank Dual with Demand Pump - Optional

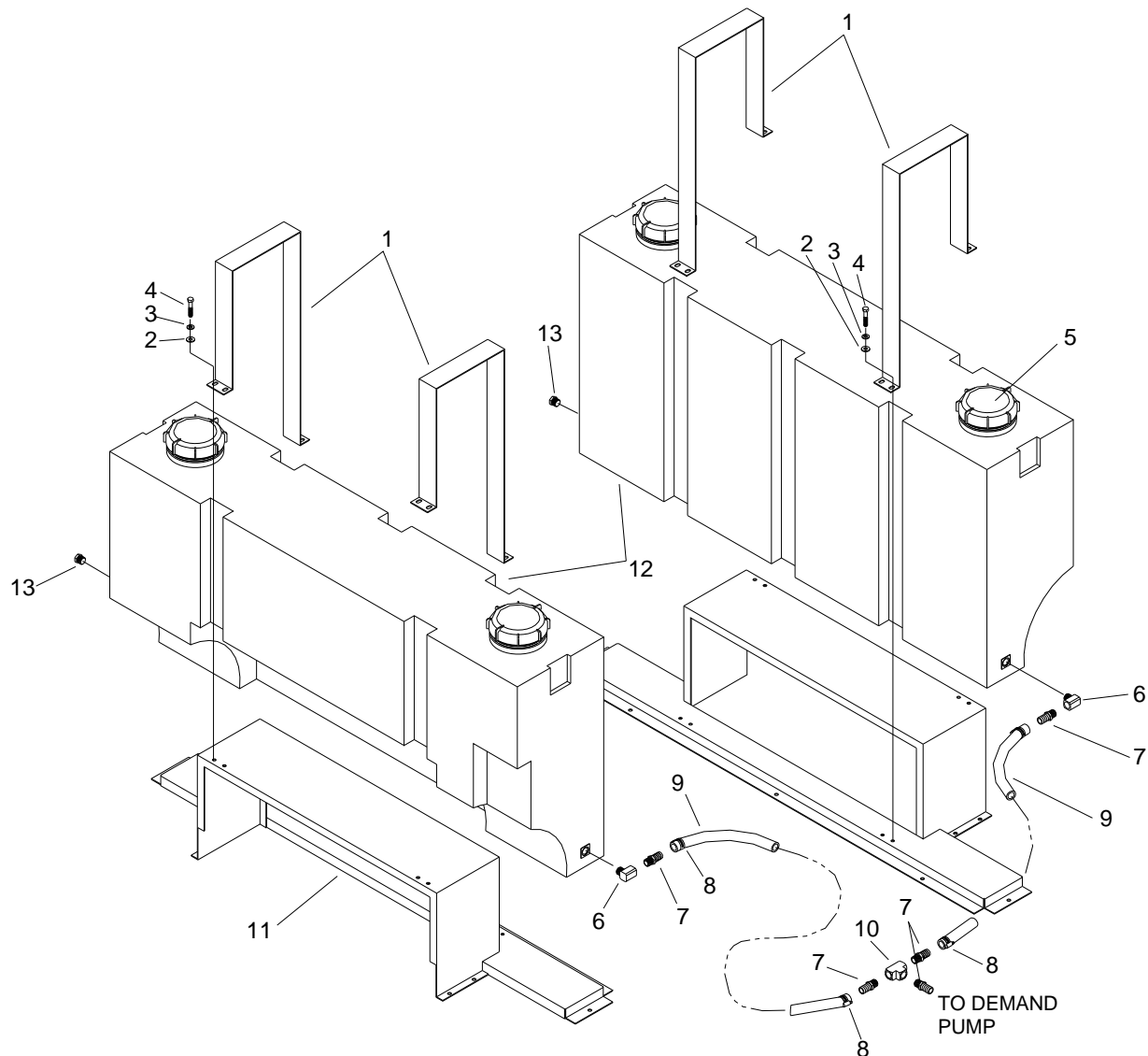

OVERALL DIMENSION:
 32-1/2" TALL
 62-5/8" WIDE
 15-1/2" DEEP

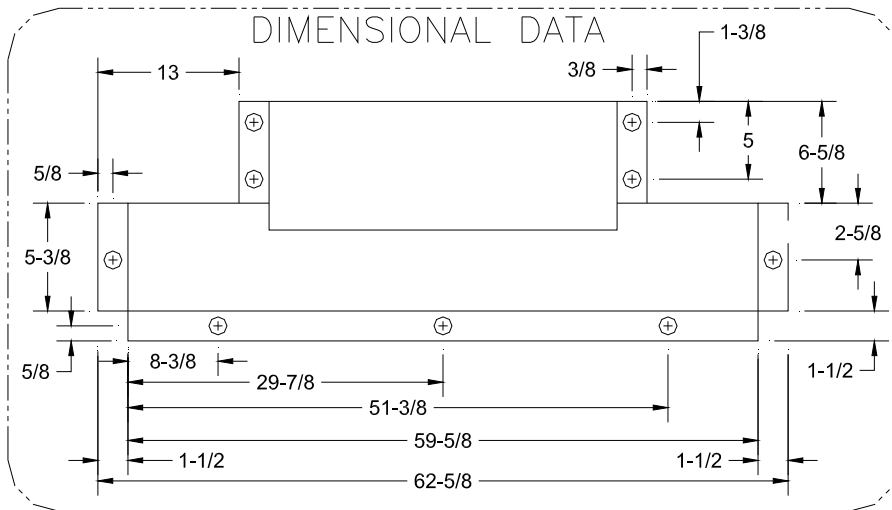
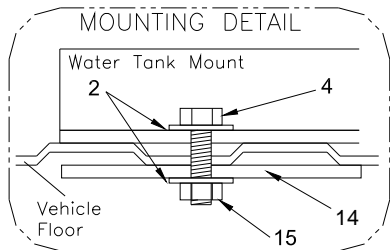

Water Tank Dual with Demand Pump - Optional

REF	PART NO.	QTY	DESCRIPTION	SERIAL NO. FROM	NOTES
-	86041730	-	TANK, DUAL SADDLE W/DMD PUMP		COMPLETE
-	86041710	-	SINGLE SADDLE TANK W/DMND PMP		COMPLETE
1	86048310	4	HOLD DOWN, SADDLE TANK GRAY		
2	86279510	16	WASHER, 3/8 FLAT		
3	86010790	16	WASHER 3/8 SPLIT LOCK		
4	86277830	16	SCR, 3/8-16 X 2' HXHD		
5	86176400	4	CAP, WATER BOX		
6	86180170	2	ELL, STREET 1/2 BR		
7	86181370	5	FTTG, BRB 1/2P X 3/4H BR		
8	86177310	4	CLMP, HOSE #16 1-1/2 MIN 1-3/4		
9	86280590	1	HOSE, WTR 3/4 X 96		
10	86194120	1	TEE, 1/2 BRASS		
11	86043320	2	ASSY, BASE SADDLE TANK GRAY		
12	86030990	2	MOLDING, WATER TANK		
13	86190500	2	PLUG, 1/2 BRASS HXHD		
14	86190170	8	PLATE, INSTALL MT		
15	86005770	9	NUT, 3/8-16 HEX NYLOCK		
-	86285190	1	SHLR, CHEM, 10-GAL JUG		

Water Tank - Demand Pump - Optional

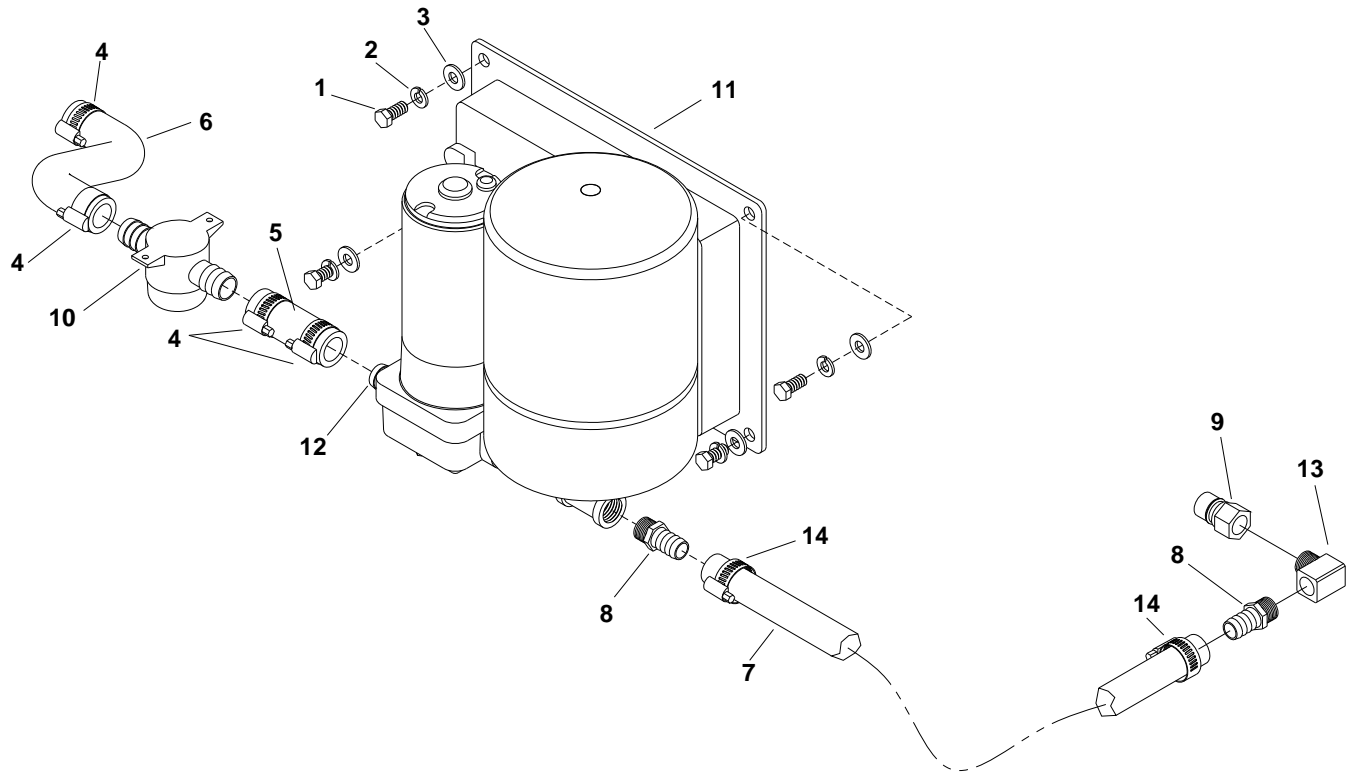

REF	PART NO.	QTY	DESCRIPTION	SERIAL NO. FROM	NOTES
-	86191390	1	PUMP ONLY, TM DEMAND		
-	86186030	1	KIT SERVICE DEMAND PMP		
1	86006760	4	SCR, 5/16-18 X 3/4 HHCS GR5 PL TDL		
2	86279130	4	WASHER, 5/16 SPLIT LOCK PLTD		
3	86278830	4	WASHER, 5/16 FLAT		
4	86177310	4	CLMP, HOSE #16 1-1/2 MIN 1-3/4		
5	86400880	1	HOSE, 3/4 ID WTR X 4.5"		
6	86410850	1	HOSE, 3/4" ID X 5.5"		
7	86280550	1	HOSE, 5/8ID X 55"		
8	86181400	1	FTTG, BRB 3/8P X 5/8H BR		
9	86179630	1	DISCONNECT, 3/8M X 3/8FP		
10	86180900	1	FILTER, DEMAND PUMP		
11	86190740	1	PUMP, WATER BOOSTER		
12	86186120	1	KIT, PORT		
13	86180210	1	ELBOW, ST 3/8 BR		
14	86177260	2	CLMP,HOS#10 9/16MIN 1-1/		
-	86370150	1	ASSEMBLY, 40 PSI PRESS SWITCH		NOT SHOWN

Auxiliary Water Tank with Pump-Optional

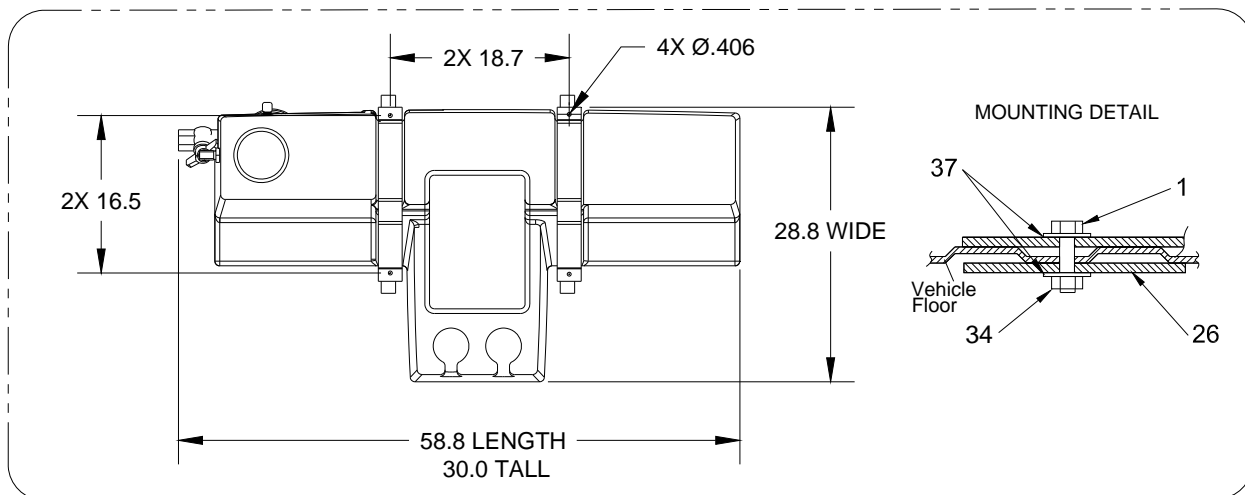
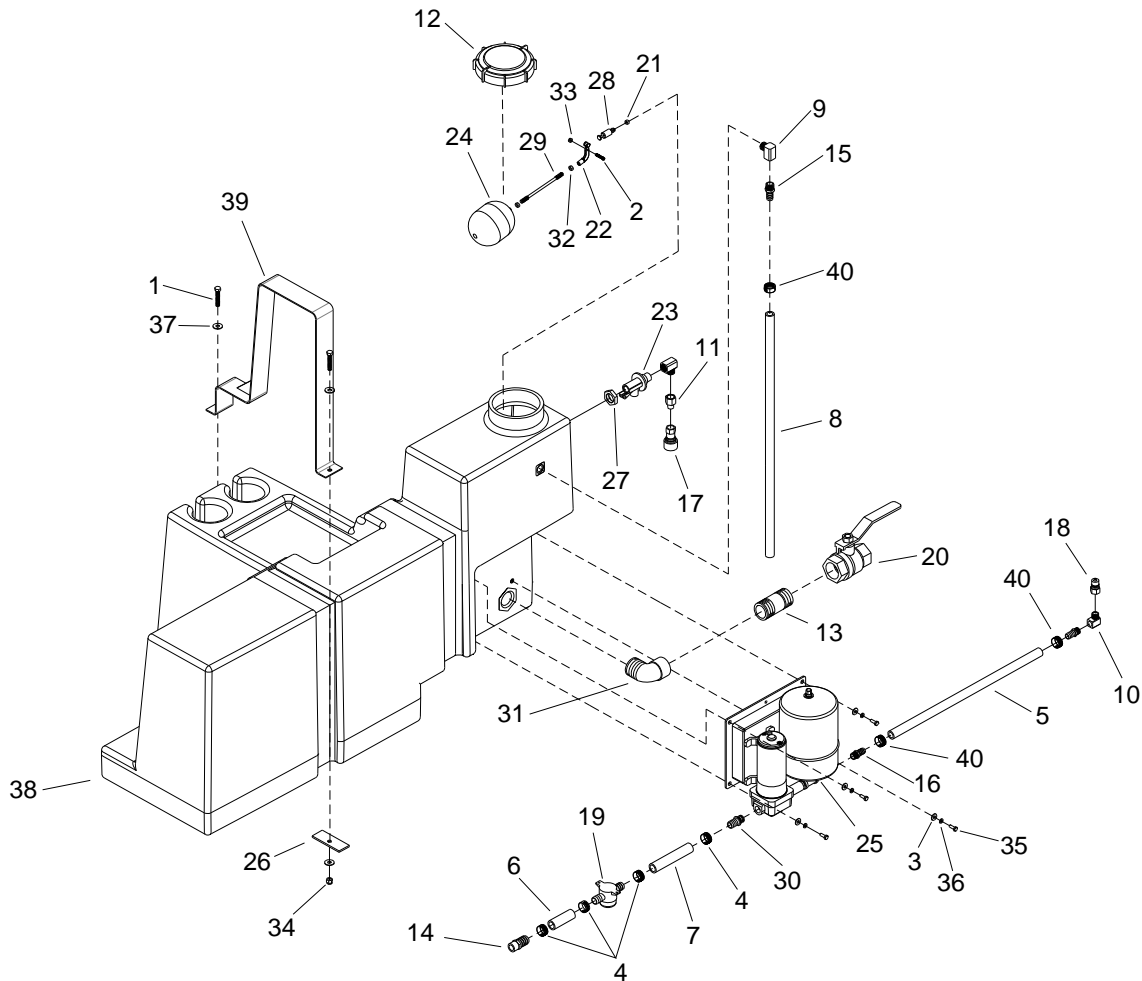

Auxiliary Water Tank with Pump-Optional

REF	PART NO.	QTY	DESCRIPTION	SERIAL NO. FROM	NOTES
-	86041580	1	ASSY, AUX WTR TNK W/PMP		COMPLETE
1	86277830	4	SCR, 3/8-16 X 2" HXHD		
2	86277850	1	SCR, 10-32 X 1" SOCHD SST		
3	86270330	4	FLATWASHER, 1/4		
4	86177310	4	CLMP, HOSE #16 1-1/2 MIN 1-3/4		
5	86280550	1	HOSE, 5/8 ID X 55"		
6	86410800	1	HOSE, 3/4" ID X 3"		
7	86410850	1	HOSE, 3/4" ID X 5.5"		
8	86280140	1	HOSE, 5/8 ID X 30 1/2		
9	86180170	2	ELL, STREET 1/2 BR MACH		
10	86180210	1	ELL, ST 3/8 BR		
11	86191600	1	RED, 1/2FP X 3/8P BR		
12	86176400	1	CAP, WATER BOX		
13	86188480	1	NIP, 3/4 X 2-1/2 BR		
14	86181320	1	FTTG, BRB 3/4PX3/4H BR		
15	86181360	1	FTTG, BRB 1/2 X 5/8H BR		
16	86181400	2	FTTG, BRB 3/8P X 5/8 BR		
17	86179710	1	DISCONNECT 3/8F X 3/8FP		
18	86179630	1	DISCONNECT 3/8M X 3/8FP		
19	86180900	1	FILTER, DEMAND PUMP		
20	86195330	1	VLV, BALL 3/4FP BS		
21	86192380	1	SEAT, FLOAT VLV TM		
22	86173820	1	ARM, PIVOT-FH VLV		
23	86174610	1	BDY, FLOAT VLV		
24	86348200	1	BALL, 4" DIA X 5"L, WHITE FLOAT		
25	86190740	1	PMP, WTR BOOSTER FLOJET 2		
26	86190170	4	PLATE, INSTALL MT		
27	86189010	1	NUT, FLOAT VALVE		
28	86028860	1	PISTON, FLOAT VLV PISTON		
29	86181150	1	FLOAT ROD, TM		
30	86186120	1	KIT, PORT DEMAND PUMP		
31	86180260	1	ELL, 3/4 ST BR		
32	86270770	2	NUT, 1/4-20 HEX		
33	86270990	1	NUT, 10-32 HEX NYLOCK SS		
34	86005770	4	NUT, 3/8-16 HEX NYLOCK		
35	86274750	4	SCR, 1/4-20 X 3/4 HHCS PLTD		
36	86010780	4	WASHER, 1/4 SPLIT LOCK PLTD		
37	86279510	8	WASHER, 3/8 FLAT		
38	86369300	1	TNK, FRESH WATER 70G		
39	86369410	2	WELDMENT, WTR CNSL TNK STRAP		
40	86177260	3	CLMP, HOS#10 9/16MIN 1-1/		
-	86261290	1	HARNESS, WTR PMP SADDLE TANK		NOT SHOWN

Auxiliary Water Tank - Optional

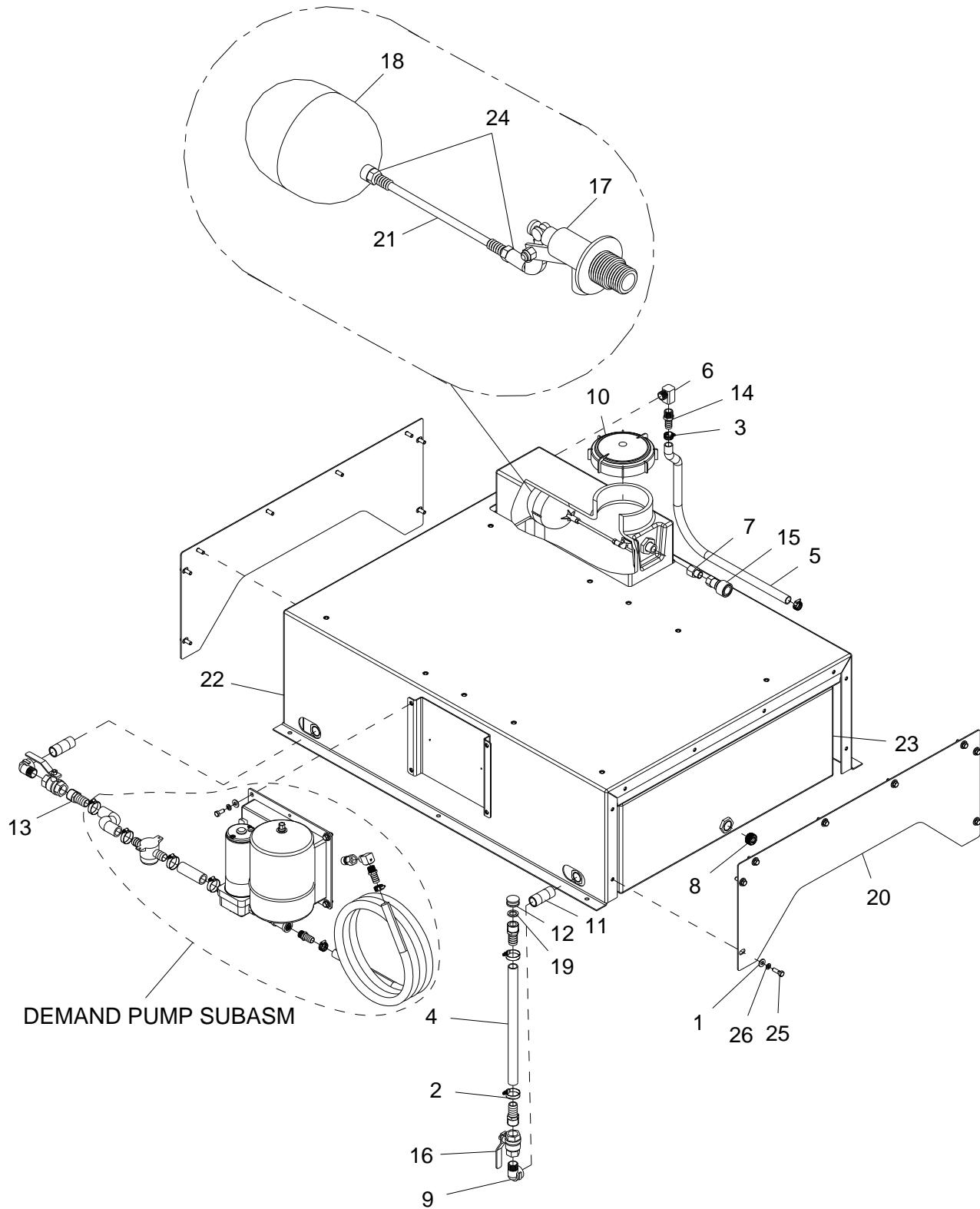

REF	PART NO.	QTY	DESCRIPTION	SERIAL NO. FROM	NOTES
-	86412440	-	SUB-ASSY, 60G WTR TNK PC, GRY		COMPLETE
1	86278830	20	WASHER, 5/16 FLAT PLTD		
2	86177310	6	CLMP, HOSE #16 1-1/2 MIN 1-3/4		
3	86177260	4	CLMP,HOS#10 9/16MIN 1-1/		
4	86280060	1	HOS, 3/4ID WTR X 13.5"		
5	86410760	1	HOSE, 5/8" ID X 27"		
6	86180170	1	ELL, STREET 1/2 BR MACH		
7	86191600	1	RED, 1/2FP X 3/8P BR		
8	86190190	1	PLG, 3/4 SOCHD BR		
9	86180260	2	ELL, 3/4 ST BR		
10	86176400	1	CAP, WATER BOX		
11	86188480	2	NIP,3/4 X 2-1/2 BR		
12	86176420	1	CAP, HOS 3/4 BR		
13	86181320	3	FTTG, BRB 3/8P X 3/4H BR		
14	86181360	1	FTTG, BRB 1/2P X 5/8H BR		
15	86179710	1	DSC, 3/8F X 3/8FP		
16	86195330	2	VLV, BALL 3/4 BS		
17	86195060	1	VALVE, FLOAT, TM		
18	86348200	1	BALL, 4" DIA X 5"L, WHITE FLOAT		
19	86195820	1	WSR, HOS 5/8ID 1"OD		
20	86412400	2	PL, FRT TANK SUPPORT, GRY		
21	86181150	1	ROD, FLOAT 1/4-20 X 6" SS		
22	86412390	1	ENCL, TNK SUPT W/DEM PMP, GRY		
23	86030970	1	MLDG, WTR TNK, 60G W/OVRFI		
24	86270770	2	NUT, 1/4-20 HEX		
25	86006750	16	SCR, 5/16-18 X 1.00 HHCS GR5		
26	86279130	20	WASHER, 5/16 SPLIT		

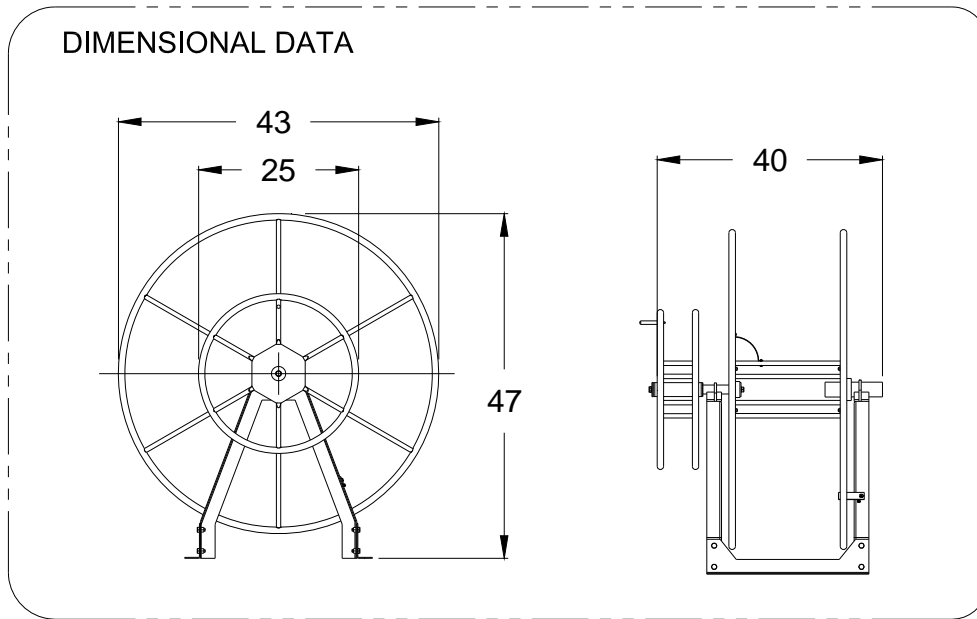

OVERALL DIMENSIONS: 47" TALL
40" WIDE

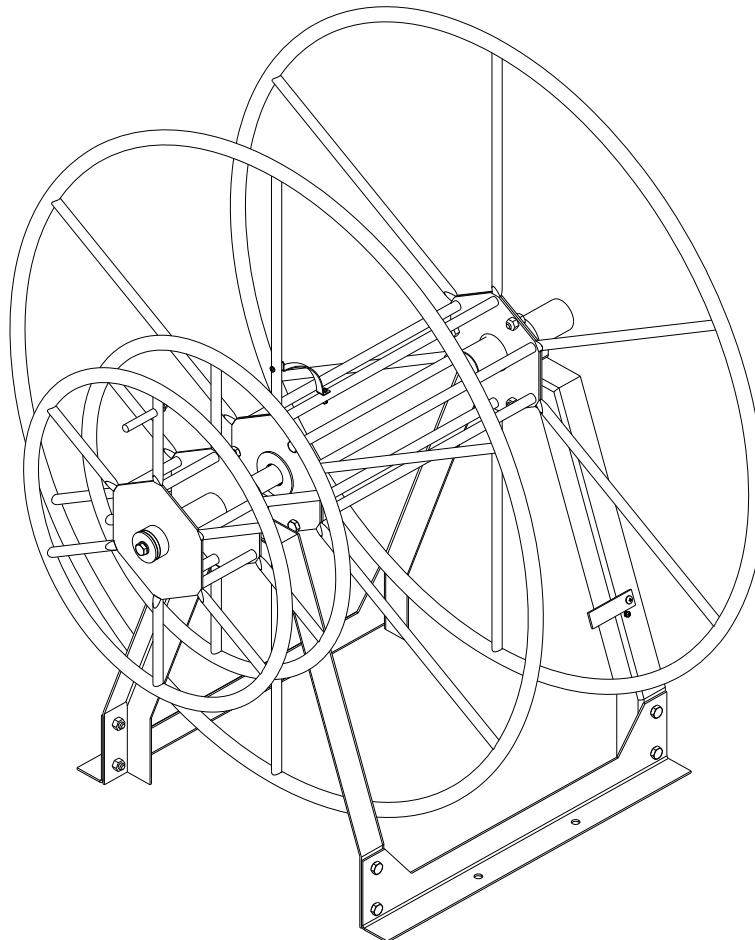

REF	PART NO.	QTY	DESCRIPTION	SERIAL NO. FROM	NOTES
-	86373960	1	HOSE REEL, 300 FT W/SMALL REEL		COMPLETE

Motorized Hose Reel - Tank - Optional

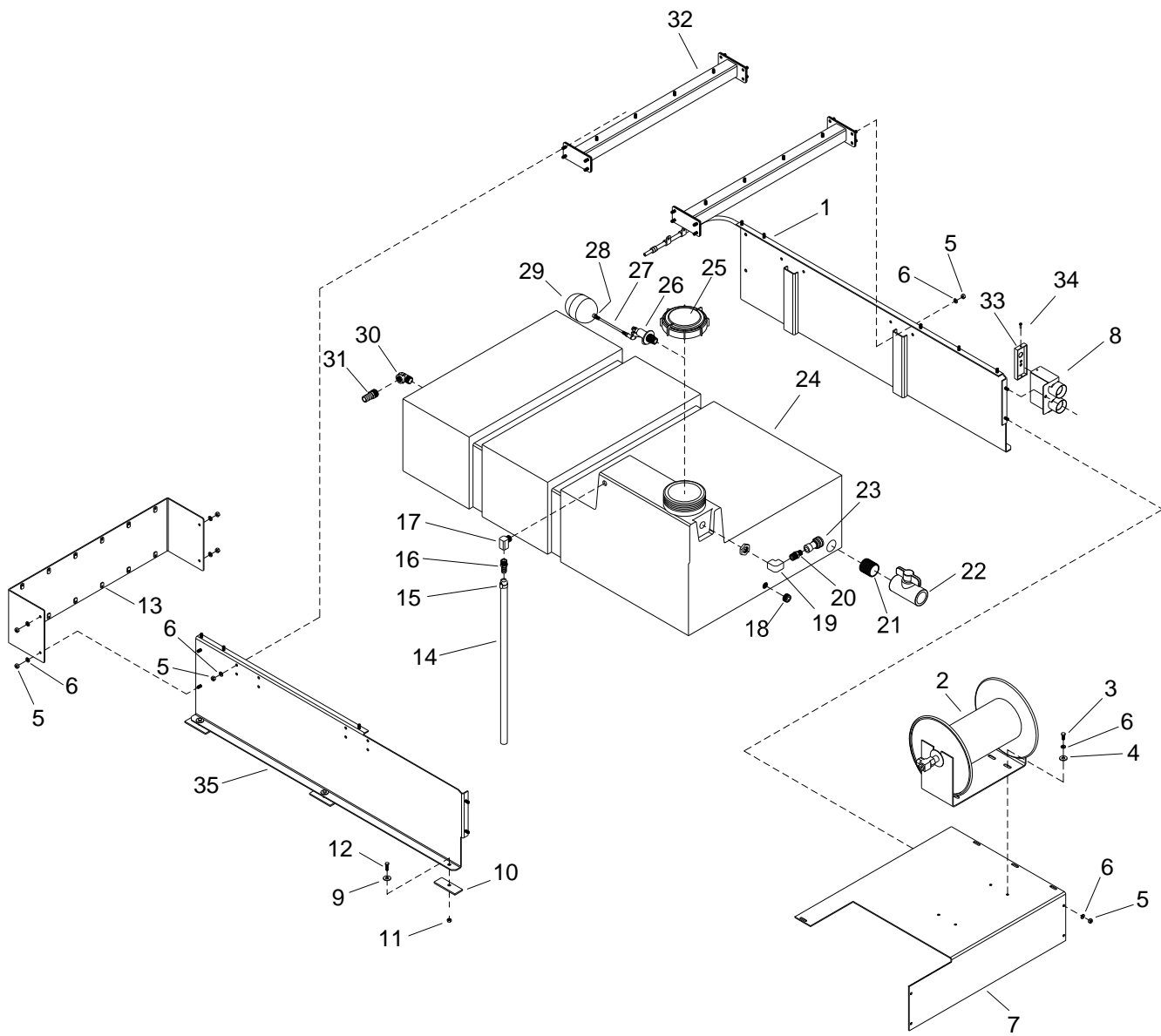

REF	PART NO.	QTY	DESCRIPTION	SERIAL NO. FROM	NOTES
-	86412620	1	MOTORIZED HOSE REEL PC, GRY		COMPLETE
1	86412630	1	BASE, RT SD HOE RL MTR, GRY		▲
2	86191830	1	RL, HOS HP SOL		
3	86006760	4	SCR, 5/16-18 X 3/4 HHCS		
4	86278830	4	WASHER, 5/16 FLAT PLTD		
5	86005650	24	NUT, 5/16-18 HEX		
6	86279130	28	WASHER, 5/16 SPLIT LOCK PLTD		
7	86412650	1	BASE, HOS RL FRT & TOP, GRY		▲
8	86046520	1	BX, SW HOS RL MTR		
9	86279510	6	WASHER, 3/8 FLAT		
10	86190170	6	PLATE, INSTALL MT		
11	86005770	6	NUT, 3/8-16 HEX NYLOCK		
12	86275150	6	SCR, 3/8-16 X 1 3/4 HHCS PLT		
13	86412660	1	PNL, DEMAND PMP MT, GRY		▲
14	86410760	1	HOSE, 5/8" ID X 27"		
15	86177310	2	CLMP, HOSE #16 1-1/2 MIN 1-3/4		
16	86181360	1	FTTG, BRB 1/2P X 5/8 BR		
17	86180170	1	ELL, STREET 1/2 BR		
18	86190190	1	PLG, 3/4 SOCHD BR		
19	86180250	1	ELL, 1/2 BR		
20	86188210	1	NIP, 1/2 X 3/8 HEX BR		
21	86188470	1	NIP, 1-1/2 X CL PVC (SCH80)		
22	86195010	1	VALVE, BALL PVC 1-1/2FP		
23	86179710	1	DSC, 3/8F X 3/8FP		
24	86030980	1	MLDG, WTR TANK 95GAL W/OVERFLW		
25	86176400	1	CAP, WATER BOX		
26	86195060	1	VALVE, FLOAT		
27	86181150	1	FLT ROD		
28	86270770	1	NUT, 1/4-20 HEX		
29	86348200	1	BALL, 4" DIA X 5"L, WHITE FLOAT		
30	86180260	1	ELL, 3/4 ST BR		
31	86181320	1	FTTG, BRB 3/4P X 3/4H BR		
32	86412670	2	BASE, CROSS BAR TB HS RL, GRY		▲
33	86051770	1	PNL, SW BX CVR PLT MTR		
34	86161960	3	SCR, #8 X 1/2 PPHST BLK		
35	86412640	1	BASE, LF SD HOS RL MTR DR, GRY		▲
-	86261360	1	CABLE, RETAIN VAC PLG		

▲ WHEN ORDERING INDICATE PART NUMBER AND COLOR

Motorized Hose Reel - Optional

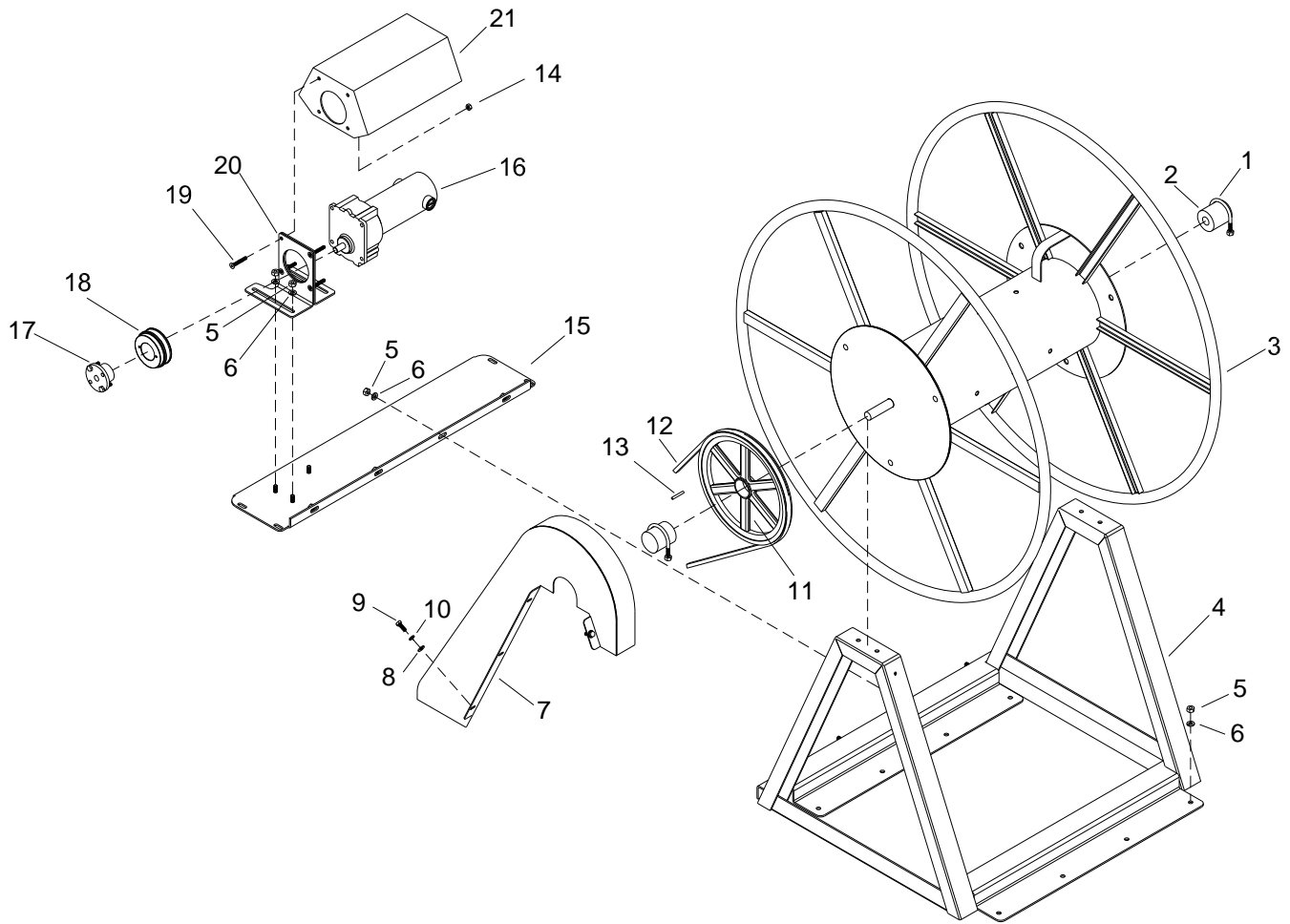

REF	PART NO.	QTY	DESCRIPTION	SERIAL NO. FROM	NOTES
1	86177270	2	CLAMP, MFLR 1-3/4		
2	86175990	2	BUSHING, HOSE REEL		
3	86412680	1	RL,VAC HOS-HOS RL MTR DR		▲
4	86412690	1	BASE, MTR HOSE REEL, GRY		▲
5	86005650	16	NUT, 5/16-18 HEX		
6	86279130	16	WASHER, 5/16 SPLIT LOCK PLTD		
7	86047910	1	GUARD, BELT MOTORIZED REEL		
8	86270330	4	FLATWASHER, 1/4		
9	86274750	4	SCR, 1/4-20 X 3/4 HHCS PLTD		
10	86010780	4	WASHER, 1/4 SPLIT LOCK PLTD		
11	86191090	1	PULL, AK104		
12	86324350	1	BELT, AX66 GOODYEAR MATCH		
13	86135960	1	KEY, 3/16 X 1 1/8		
14	86270770	4	NUT, 1/4-20 HEX		
15	86412700	1	BASE, MTR MT PNL HOS RL, GRY		▲
16	86187870	1	MOT, 1/8HP 12V EP5786		
17	86185360	1	HUB, H1/2		
18	86191100	1	PULL, AK32H		
19	86192100	4	SCR, CAP 1/4-20 X 1-1/2 FLT		
20	86050110	1	MT, MTR HOS RL MTR DRIVE		
21	86047450	1	CVR, HOS RL MTR CVR		

▲ WHEN ORDERING INDICATE PART NUMBER AND COLOR

E Z - Charge Water Softener - Tank & Tray - Optional

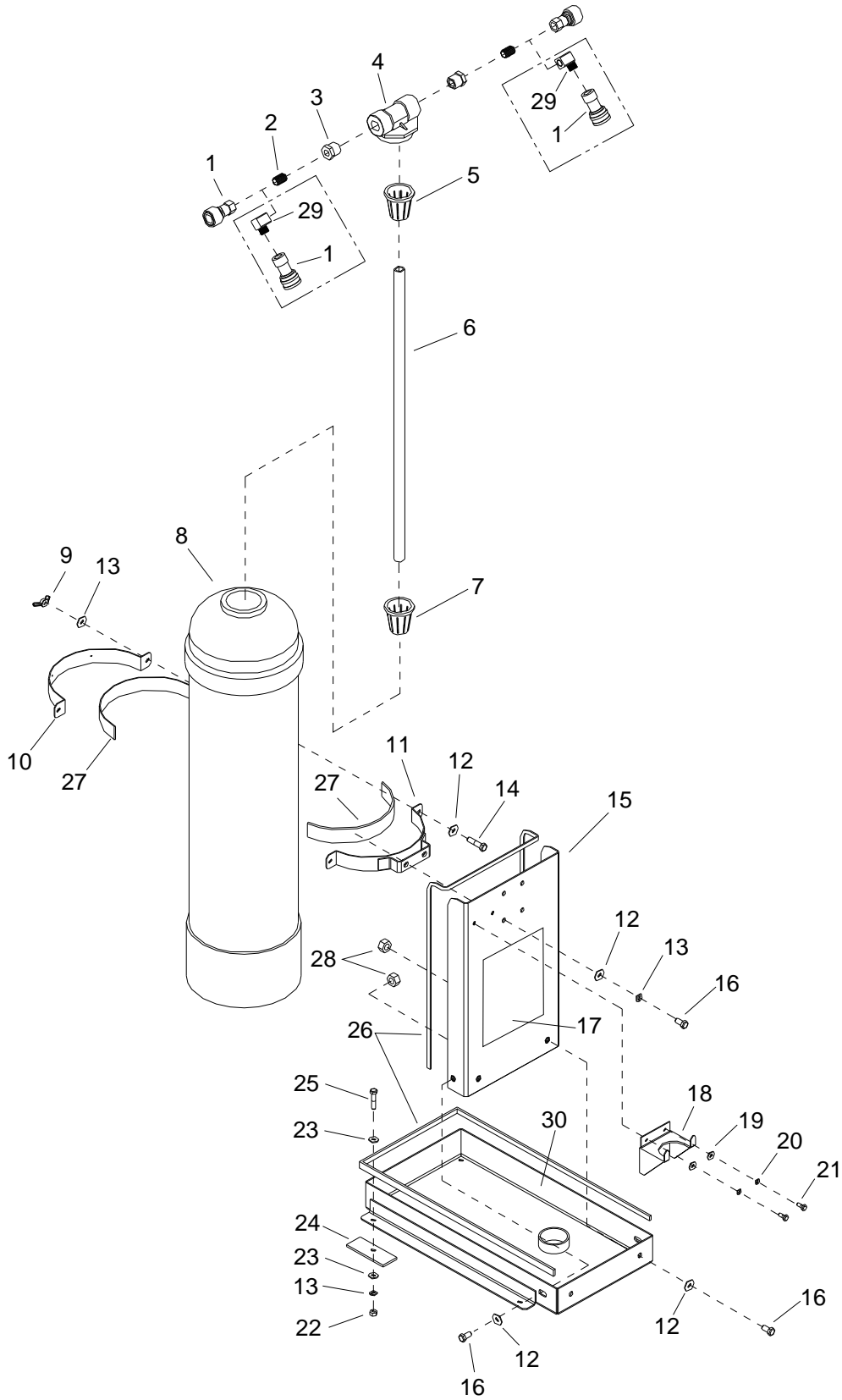

E Z - Charge Water Softener - Tank & Tray - Optional

REF	PART NO.	QTY	DESCRIPTION	SERIAL NO. FROM	NOTES
-	86041740	1	WATER SOFTENER 30" PC		COMPLETE
1	86179710	2	DCS, 3/8F X 3/8FP		
2	86188220	2	NIP, 3/8 X CL SST		
3	86175880	2	BUSH, 3/4 X 3/8 ALUM		
4	86173650	1	ADPT, TNK#50-0271		
5	86179650	1	DIST, TOP #41-2514		
6	86057920	1	TB, PVC 13/16X27"		
7	86177590	1	COLLECTOR, LWR #41-2410		
8	86349450	1	TANK, WATER SOFTNER, BLUE 30"		
9	86270710	2	NUT, WING 3/8-16		
10	86057120	1	STRAP, WTR, SOFT CLAMP		
11	86047140	1	CLAMP, TNK WTR SOFT		
12	86279510	8	WASHER, 3/8 FLAT		
13	86010790	12	WASHER, 3/8 SPLIT LOCK		
14	86275190	2	SCREW, 3/8-16 X 1.25 HHCS SS		
15	86054050	1	PNL, SOFT MTG-WTR SOFT CIR GRAY		
16	86006920	4	SCR, 3/8-16 X 3/4 HHCS GR5 PLTD		
17	86179160	1	DEC, CDNSD REGEN OPER		
18	86048330	1	HLDR, FLTR-WTR SOFT		
19	86270330	2	FLATWASHER, 1/4		
20	86010780	2	WASHER, 1/4 SPLIT LOCK PLTD		
21	86275890	2	SCR, 1/4-20 X 5/8 HHCS PLTD		
22	86005650	4	NUT, 5/16-18 HEX		
23	86278830	8	WASHER, FLAT PLTD		
24	86190170	4	PLATE, INSTALL MT		
25	86274690	4	SCR, 5/16-18 X 1.5 HHCS BR5PLT		
26	86194660	2	TRIM, FLX 1/16 X 29/64 BLK		
27	86411920	2	GSKT, FOAM-WTR SOFT 12"		
28	86005770	4	NUT, 3/8-16 HEX NYLOCK		
29	86180210	2	ELL, ST 3/8 BR		OPTIONAL
30	86349090	1	TRAY, RECT, WTR SOFTNER		
-	86189750	1	PAPER,WTR HARDNESS		NOT SHOWN

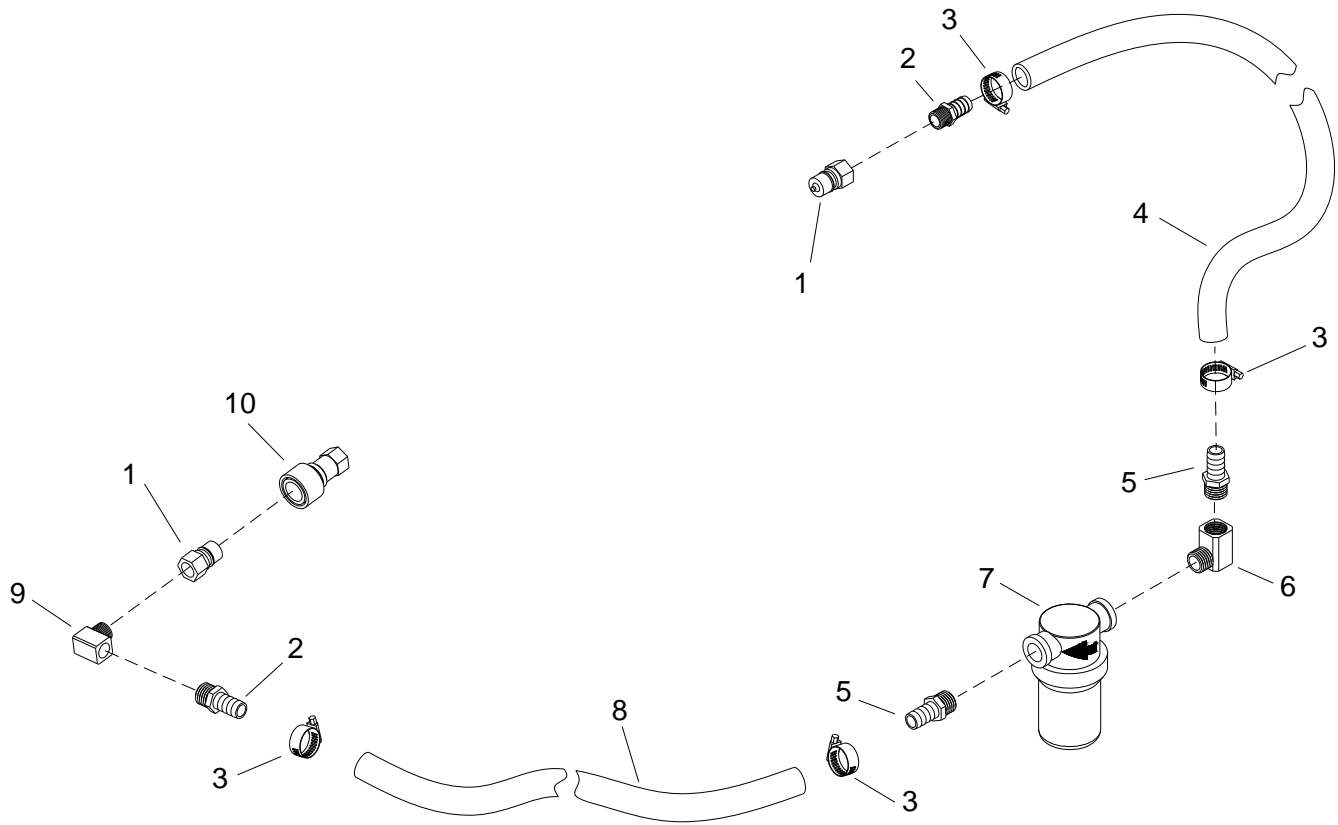

E Z - Charge Water Softener - Filter - Optional

REF	PART NO.	QTY	DESCRIPTION	SERIAL NO. FROM	NOTES
1	86179630	1	DISCONNECT, 3/8M X 3/8FP		
2	86181400	2	FTTG, BRB 3/8P X 5/8H BR		
3	86177260	4	CLMP, HOS#10 9/16MIN		
4	86280140	1	HOSE, WTR 5/8X 30-1/2		
5	86181360	2	FTTG, BRB 1/2P X 5/8H BR		
6	86180170	1	ELL, STREET 1/2 BR		
7	86193510	1	STRNR, IN-LINE 1/2FP BS		
8	86412110	1	HOSE, 5/8" ID X 97"		
9	86180210	1	ELL, ST 3/8 BR		
10	86179710	1	DSC, 3/8F X 3/8FP		

E Z - Charge Water Softener - Brine System - Optional

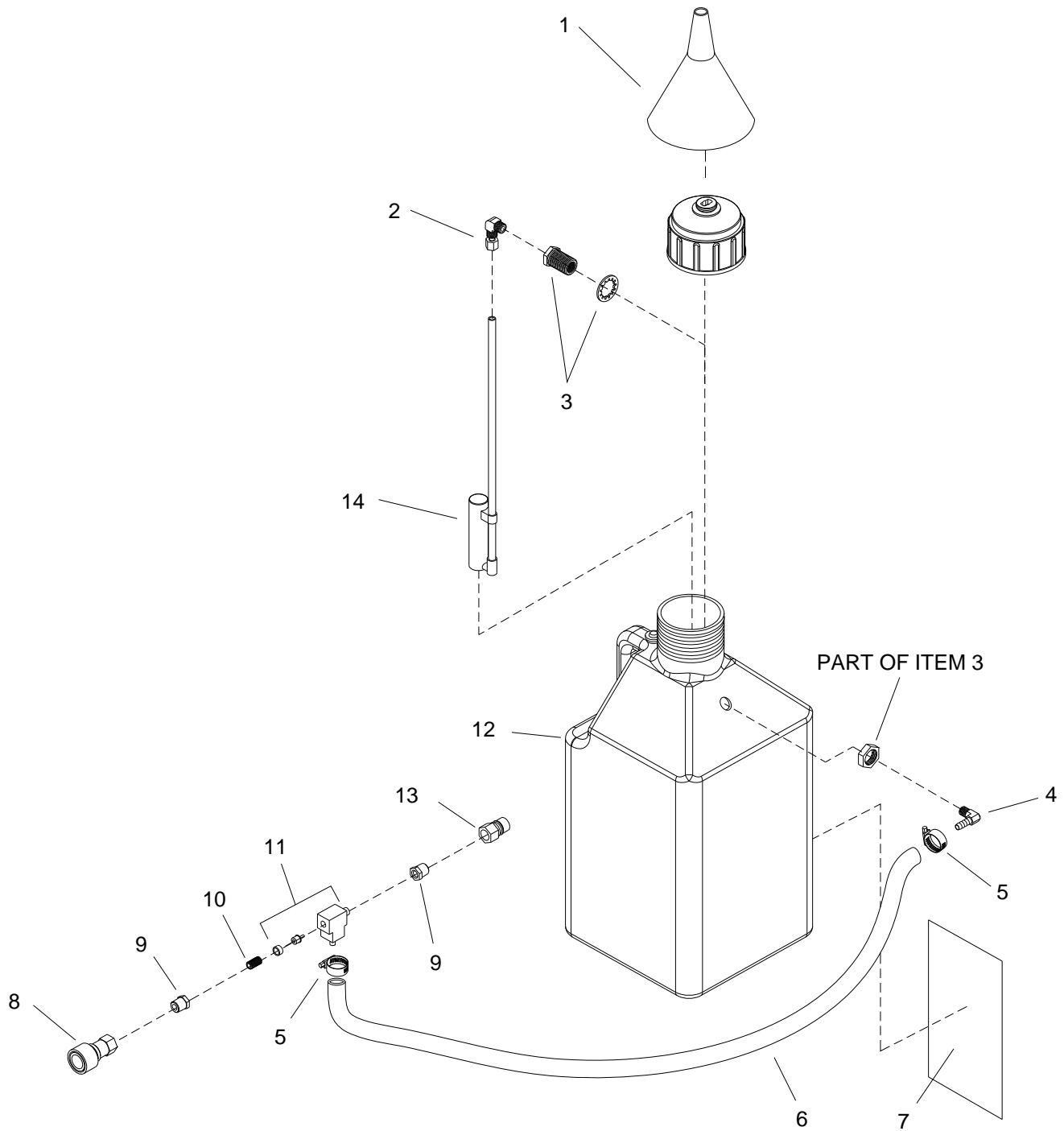

E Z - Charge Water Softener - Brine System - Optional

REF	PART NO.	QTY	DESCRIPTION	SERIAL NO. FROM	NOTES
1	86195930	1	FUNNEL, BIG BLU		
2	86180470	1	ELL, 1/4P X 3/8 POLY BR		
3	86177620	1	CONN, 1/4P BLKHD LNG BR		
4	86180480	1	ELL, BRB 1/4P X 1/4H BR		
5	86176990	2	CLAMP, HOSE #4 SST		
6	86280630	1	HOSE, 1/4ID NYLOBRD X 30"		
7	86179160	1	DEC, CDNSD REGEN OPER		
8	86179710	1	DSC, 3/8F X 3/8FP		
9	86175920	2	BUSH, 3/8 X 1/8 BR		
10	86247720	1	NIPPLE, 1/8 CLOSE		
11	86195460	1	VLV, INJ W/#1JET		
12	86185720	1	JUG, 5 GAL		
13	86179630	1	DISCONNECT 3/8M X 3/8FP		
14	86195410	1	VLV,AIR CHK W/STEM PURCH'D		

Serial Number

REF. NO.	MODEL: SERIAL #
1	10011190004134, 10011380000012, 10011410000001, 10011620000040

